

INSTALLATION INSTRUCTIONS



Handling and Storage of pipes

Do not use metallic slings as these can cause cuts and gouges.

Ensure that pipes and fittings do not come into contact with oils/solvents or heat sources (The materials are flammable).

Avoid contact with sharp objects and do not drag pipes across the ground.

Ensure that any end caps supplied in pipes or fittings remain in place until jointing commences. For storage periods outdoors longer than 12 months blue products should be stored under cover.

Particular care should be exercised when handling pipes/fittings in wet or frosty conditions as the pipes/fittings will be slippery and difficult to handle.

Installation

Polypipe Polyethylene Pipe systems should be installed in accordance with the Water Industries Manual for PE pipe systems for Water Supply and the Codes of Practice for PE Pipework CP312 Parts 1 and 3.

The normal minimum depth of cover for service pipes is 750mm.

In uniform, soft soils free from sharp stones having a compaction fraction of less than 0.3, the pipes can be laid on the trimmed trench bottom and the as-dug soil can be used for side and backfill.

Thorough compaction by hand should be carried out until 250mm depth of cover is placed above the pipe following which machine compaction can be used. If the as-dug material is not suitable, then the trench should be excavated 100mm below the centre of the pipe and imported granular or similar bedding and fill in accordance with WIS 4.08.01 should be used. Polyethylene pipe systems are not suitable for use as an electrical earth.

Testing

Pressure test to 1.5 times the actual working pressure for one hour maximum before connecting the installation to the mains supply.

Any permissible fall off in pressure after isolating from the pressure source will be determined by the Site Engineer in accordance with the WRC Manual for PE Pipe Systems. Sanitisation of the pipework prior to connection to carry Potable Water should be in accordance with the recommended procedure of the responsible Water Company.

20mm to 63mm Fittings Applications

Polyfast Compression Fittings: an economical compression system for joining MDPE, LDPE, HDPE, normal gauge and heavy gauge polyethylene, copper, lead, PVCu and Galvanized Steel.



POLYFAST ADAPTOR SET JOINTING INSTRUCTIONS



Polyethylene Pipe Jointing Instructions

Note: Always check that the factory applied silicone lubricant grease is present on the rubber seal.

There are 5 Vital stages to successfully join Polyfast Compression fittings to blue (BS6572) and black (BS6730) MDPE pipe.



1 Always use one of the approved pipe cutters (Code 781 or 778). A slight rotation of the pipe when cutting will help make the operation easier. **Never use a hacksaw.** Cut pipe end square and remove any burrs or sharp edges.

2. Insert pipe stiffener in pipe up to the stop.

3. Loosen nut on Polyfast fittings.



4. Insert clean pipe to full socket depth and re-hand tighten the polyfast nut to secure, plus 1/8 of a turn using a strap wrench (Code: 780) **Do not over tighten.**

Polyethylene pipe cannot be used as an electrical earth.

Hand tighten plus 1/8 turn using strap wrench.

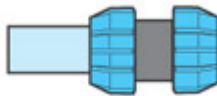

MDPE Reducing Set

(a) Remove nut from fitting and place over pipe end.

(b) Discard black/grey metric grab ring.

(c) Place nut reducer and new black grab ring over pipe end (thickest section towards fitting body) Ensure the grab ring is positioned at the end of the pipe.

(d) Insert barbed end of adaptor into pipe and tap in with wooden mallet up to flange.

(e) Push black grab ring up to flange, if necessary.

(f) Push spigot end of adaptor into body of fitting to full socket depth. Engage nut onto fitting.

(g) Hand tighten plus 1/8 turn using strap wrench.



LDPE and HDPE Black

BS1972: 1967 C&D BS3284 C&D

BS1972: 1961 (IS134 NG & HG)

(a) Remove nut from fitting and place over pipe end.

(b) Discard black/grey metric grab ring.

(c) Place white imperial grab ring over pipe (thickest section towards fitting body). Ensure the grab ring is positioned at the end of the pipe.

(d) Insert barbed end of adaptor into pipe and tap in with wooden mallet up to flange.

(e) Push spigot end of adaptor into body of fitting to full socket depth. Engage nut onto fitting.

(f) Hand tighten plus 1/8 turn using strap wrench.



Copper BS2871 Table X & Y (EN1057)

(a) Remove nut from fitting and place over pipe end.

(b) Place black or grey metric grab ring over pipe (thickest section towards fitting body).

(c) Place over pipe stainless steel washer, stainless steel grab ring (taper towards pipe end) and then other stainless steel washer maximum 15mm from end.

(d) Push rubber bush, flange first onto pipe, maintaining close contact with other components up to stop of rubber bush.

(e) Push spigot end of rubber bush into body of fitting to full socket depth. Engage nut on fitting.

(f) Hand tighten plus 1/2 turn using strap wrench.



Lead BS602, 1085/1970 NB Use 3/8" in 20mm body, 1/2" in 25mm body, 3/4" in 32mm body, and 1" in 40mm body.

(a) Remove nut from fitting and place over pipe end.

(b) Discard black/grey metric grab ring.

(c) Place white grab ring over pipe (thickest section towards fitting body). Ensure the grab ring is positioned at the end of the pipe.

(d) Insert barbed end of adaptor into pipe and tap in with wooden mallet up to flange.

(e) Push white grab ring up to flange, if necessary.

(f) Push spigot end of adaptor into body of fitting to full socket depth. Engage nut on fitting.

(g) Hand tighten plus 1/2 turn using strap wrench.

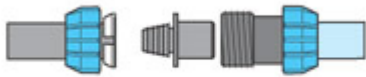

PVCu BS3505/6 1968 **Galvanised Steel** BS1387

(a) Remove nut from fitting and place over pipe end

(b) Discard black metric split grab ring

(c) Push rubber bush onto end of pipe

(d) Push spigot end of rubber bush into body of fitting to full socket depth. Engage nut onto fitting

(e) Hand tighten plus 1/2 turn using strap wrench.



NB: Not end load bearing. Must be anchored to prevent pullout.

Imperial Adaptor Couplers for LDPE/hdpe Pipes

BS 1972: 1967/BS 3284: 1967

(a) Note that the imperial end of the fitting has a Black nut.

Cut the pipe end square with the axis and file a chamfer onto the pipe end.

(b) Insert the pipe end through the black nut, grab-ring and the rubber seal to full socket depth.

(c) Hand tighten plus 1/8 turn using strap wrench.
(Note: Do not over tighten).

Wide Tolerance Adaptor Couplers for Lead Pipes

BS 602, 1085: 1970

(a) Check condition of pipe surface and cut back pipe square to remove any surface grooves or damage using pipe cutters or saw, deburr and chamfer end of pipe to facilitate assembly.

(b) Remove the nut from the fitting and replace the nut over the pipe end.

(c) Mark the socket depth on the pipe and push the grab-ring up to the mark (thickest section toward fitting body).

(d) Push the seal onto the pipe and up to the grab-ring (tapered face towards fitting).

(e) Position the lead pipe, seal and grab-ring into the fitting body, engage the thread.

(f) Hand tighten plus 1/4 turn using strap wrench.
(Note: Do not over tighten).

High Flow Reducing Set For MDPE pipes

Plastic reducing bushes 63 x 20mm (Code: 4806320) 63 x 25mm

(Code: 4806325) 63mm x 32mm (Code: 4806332) 50 x 20mm (Code: 4805020) 50 x 25mm (Code: 4805025) 32 x 20mm (Code: 4803220)

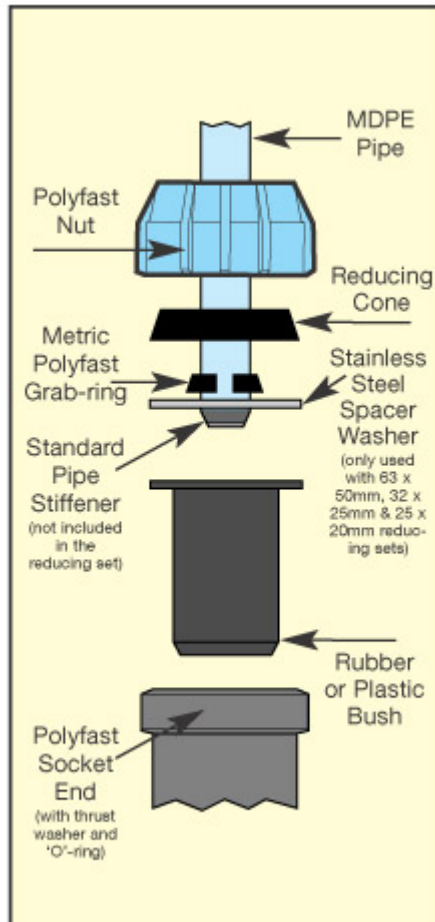

(a) Cut pipe square and fit standard Polyfast pipe stiffener.

(b) Select the appropriate reducing set for the size of polyfast fitting and the smaller pipe to be fitted (eg. 63mm x 20mm reducing set, Code: 4806320).

(c) Remove the nut from the Polyfast fitting and discard the standard metric grab-ring. Ensure that the seal and thrust washer remain in position in the socket.

(d) Push the plastic reducing bush into the socket of the polyfast socket until the end of the bush is flush with the end of the socket.

(e) Place the smaller grab-ring onto the reducing bush (thicker end in contact with the bush) and the reducing cone over the grab-ring and re-fit the Polyfast nut onto the end of the body.

(f) Push the pipe through the nut into the socket of the reducing bush to contact the register at the bottom of the socket.

(g) Hand tighten plus 1/8 turn using strap wrench.
(Note: Do not over tighten).

High Flow Reducing Set For MDPE pipes

Rubber bushes 63 x 50mm (Code: 4806350) 32 x 25mm (Code: 4803225) 25mm x 20mm (Code: 4802520)

(a) Cut pipe square and fit standard Polyfast pipe stiffener.

(b) Select the appropriate reducing set for the size of polyfast fitting and the smaller pipe to be fitted (eg. 63mm x 20mm reducing set, Code: 4806320).

(c) Remove the nut from the Polyfast fitting and discard the standard metric grab-ring. Ensure that the seal and thrust washer remain in the position in the socket and check that the factory applied silicone lubricant grease is present on the rubber seal.

(d) Place the nut on the pipe end followed by the reducing cone, grab-ring (thickest section towards the pipe end) and stainless steel support washer.

(e) Fit the rubber bush over the pipe end and push the stainless steel washer/grab-ring and reducing cone back down the pipe until the pipe is fully inserted into the rubber bush with a stainless steel spacer washer and grab-ring in contact with the flanged end of the rubber bush.

(f) Push the plain spigot of the rubber reducing bush into the socket of the fitting through the thrust washer and 'O'-ring and engage the nut onto the threads on the body of the fitting.

(g) Hand tighten plus 1/8 turn using strap wrench.
(Note: Do not over tighten).

Copper/Polybutylene Sockets

Polyfast MDPE x Copper/polybutylene adaptors (Code: 478) and Push-fit MDPE x Copper/polybutylene adaptors (Code: 378)

Please refer to the jointing and dismantling instruction section of the Polyplumb Hot and Cold Water Plumbing and Heating Guide earlier in this manual (pages 8, 9 and 10).

Slip Repair Couplers

To replace damaged pipe on straight runs

(a) Cut out the damaged pipe for a distance of at least the length of 2 slip couplers. Cut a replacement length of pipe, and deburr/chamfer pipe ends.

(b) Fit pipe stiffeners to pipe ends and mark half the length of the slip couplers from each pipe end with a felt-tipped pen. Remove nuts and grab rings from the 2 slip couplers and place first one nut and one grab ring on the existing pipe ends with the tapers as shown.

(c) Check that the 'O'-ring seals are lubricated and slide one slip coupler onto each pipe end, holding the thrust washer and 'O'-ring in place until the couplers are fully onto the pipe ends.

(d) Place the second nut and grab-ring of each slip coupler onto the replacement length of pipe as shown, insert the replacement length of pipe inbetween the 2 existing pipe ends.

(e) Slide the 2 slip couplers onto the replacement pipe so that they are half on the existing pipe and half on the replacement pipe using the previously marked lines for guidance. If necessary, ensure that the seals and thrust washers are pushed back into position in each socket.

(f) Slide the grab-rings back to contact the end of each socket. (It may be necessary to insert the end of a screwdriver or a piece of wood in the grab-ring slot to open the grab-ring out slightly to enable it to be moved backwards).

(g) Screw the nuts onto each socket end. Hand tighten plus 1/8 of a turn with a strap-wrench.

