

TERRAIN



Terrain Underground Drainage

Product and Installation Guide





Introduction

Using the latest plastics manufacturing technology to satisfy the requirements of today's installers, the Terrain underground range offers both rigid and foam core pipe and a comprehensive range of fittings to suit all applications.

Terrain underground products represent the benchmark for quality, supported with outstanding service levels.

Our comprehensive range of underground drainage products are suitable for commercial, industrial, housing and public sector developments. They are:

- n* Easy-to-lay
- n* Flexible, to accommodate normal ground movement
- n* Adaptable, to connect to existing drainage systems
- n* Unique products offer unrivalled installation options
- n* Suitable for commercial and domestic installations

Systems include

Solid wall pipes and fittings

Available in 82, 110 and 160mm diameters.

110 and 160mm comply with BS EN 1401 (BS 4660).

Foamcore pipe

Manufactured using the latest tri-extrusion techniques to produce a three layer pipe that is 25% lighter than standard PVC-u pipe.

Available in 110 and 160mm diameters.

Carries BBA certificate 95/3086.

Marscar Bowl

This unique product enables up to 4 inlet connections from shallow drains, discharging through a single outlet at the centre of the bowl in the base and allowing connection to underlying drain runs up to 10 metres deep without need for manholes.

Bowl shape and inlet angles create self-cleansing swirl action.



Contents

■ TERRAIN PIPE & FITTINGS	4-7
■ TERRAIN GULLIES & HOPPERS	8-9
■ TERRAIN INSPECTION CHAMBERS	10-11
■ TERRAIN REDUCERS & ADAPTORS	12-13
■ SYSTEM PLANNING	14-25
■ FURTHER INFORMATION	26

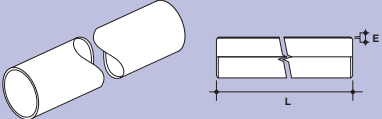
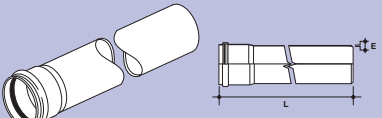
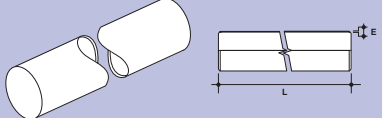
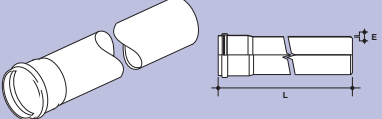
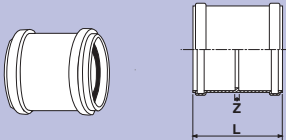
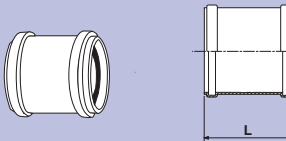
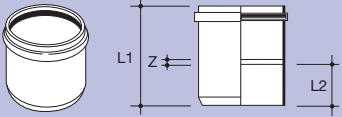
Products marked  in the product listings are available in CAD form for ready incorporation into design drawings. If you'd like a disk or CD ROM in the appropriate format, simply contact the Technical Advisory Service.

PIPE PLAIN-ENDED 	<table border="1"> <thead> <tr> <th>size(mm)</th> <th>L</th> <th>E (min)</th> </tr> </thead> <tbody> <tr> <td>82</td> <td>5.8m</td> <td>2.25</td> </tr> <tr> <td>110</td> <td>5.8m</td> <td>3.2</td> </tr> <tr> <td>160</td> <td>5.8m</td> <td>4.1</td> </tr> </tbody> </table>	size(mm)	L	E (min)	82	5.8m	2.25	110	5.8m	3.2	160	5.8m	4.1	<table border="1"> <thead> <tr> <th>Code</th> <th>Col</th> <th>Pk/bk</th> </tr> </thead> <tbody> <tr> <td>3DP58</td> <td>T</td> <td>1/88</td> </tr> <tr> <td>4DP58</td> <td>T</td> <td>1/67</td> </tr> <tr> <td>6DP58</td> <td>T</td> <td>1/33</td> </tr> </tbody> </table>	Code	Col	Pk/bk	3DP58	T	1/88	4DP58	T	1/67	6DP58	T	1/33						
size(mm)	L	E (min)																														
82	5.8m	2.25																														
110	5.8m	3.2																														
160	5.8m	4.1																														
Code	Col	Pk/bk																														
3DP58	T	1/88																														
4DP58	T	1/67																														
6DP58	T	1/33																														
PIPE SINGLE SOCKET 	<table border="1"> <thead> <tr> <th>size(mm)</th> <th>L</th> <th>E (min)</th> </tr> </thead> <tbody> <tr> <td>110</td> <td>3m</td> <td>3.2</td> </tr> <tr> <td>110</td> <td>6m</td> <td>3.2</td> </tr> <tr> <td>160</td> <td>6m</td> <td>4.1</td> </tr> </tbody> </table>	size(mm)	L	E (min)	110	3m	3.2	110	6m	3.2	160	6m	4.1	<table border="1"> <thead> <tr> <th>Code</th> <th>Col</th> <th>Pk/bk</th> </tr> </thead> <tbody> <tr> <td>4DP3S</td> <td>T</td> <td>1/67</td> </tr> <tr> <td>4DP6S</td> <td>T</td> <td>1/67</td> </tr> <tr> <td>6DP6S</td> <td>T</td> <td>1/33</td> </tr> </tbody> </table>	Code	Col	Pk/bk	4DP3S	T	1/67	4DP6S	T	1/67	6DP6S	T	1/33						
size(mm)	L	E (min)																														
110	3m	3.2																														
110	6m	3.2																														
160	6m	4.1																														
Code	Col	Pk/bk																														
4DP3S	T	1/67																														
4DP6S	T	1/67																														
6DP6S	T	1/33																														
FOAMCORE PIPE PLAIN-ENDED 	<table border="1"> <thead> <tr> <th>size(mm)</th> <th>L</th> <th>E (min)</th> </tr> </thead> <tbody> <tr> <td>110</td> <td>3m</td> <td>3.2</td> </tr> <tr> <td>110</td> <td>5.8m</td> <td>3.2</td> </tr> <tr> <td>160</td> <td>5.8m</td> <td>4.1</td> </tr> </tbody> </table>	size(mm)	L	E (min)	110	3m	3.2	110	5.8m	3.2	160	5.8m	4.1	<table border="1"> <thead> <tr> <th>Code</th> <th>Col</th> <th>Pk/bk</th> </tr> </thead> <tbody> <tr> <td>4EUP3</td> <td>T</td> <td>1/67</td> </tr> <tr> <td>4EUP58</td> <td>T</td> <td>1/67</td> </tr> <tr> <td>6EUP58</td> <td>T</td> <td>1/33</td> </tr> </tbody> </table>	Code	Col	Pk/bk	4EUP3	T	1/67	4EUP58	T	1/67	6EUP58	T	1/33						
size(mm)	L	E (min)																														
110	3m	3.2																														
110	5.8m	3.2																														
160	5.8m	4.1																														
Code	Col	Pk/bk																														
4EUP3	T	1/67																														
4EUP58	T	1/67																														
6EUP58	T	1/33																														
FOAMCORE PIPE SINGLE SOCKET 	<table border="1"> <thead> <tr> <th>size(mm)</th> <th>L</th> <th>E (min)</th> </tr> </thead> <tbody> <tr> <td>110</td> <td>3m</td> <td>3.2</td> </tr> <tr> <td>110</td> <td>6m</td> <td>3.2</td> </tr> <tr> <td>160</td> <td>3m</td> <td>4.1</td> </tr> <tr> <td>160</td> <td>6m</td> <td>4.1</td> </tr> </tbody> </table>	size(mm)	L	E (min)	110	3m	3.2	110	6m	3.2	160	3m	4.1	160	6m	4.1	<table border="1"> <thead> <tr> <th>Code</th> <th>Col</th> <th>Pk/bk</th> </tr> </thead> <tbody> <tr> <td>4EUP3S</td> <td>T</td> <td>1/67</td> </tr> <tr> <td>4EUP6S</td> <td>T</td> <td>1/67</td> </tr> <tr> <td>6EUP3S</td> <td>T</td> <td>1/33</td> </tr> <tr> <td>6EUP6S</td> <td>T</td> <td>1/33</td> </tr> </tbody> </table>	Code	Col	Pk/bk	4EUP3S	T	1/67	4EUP6S	T	1/67	6EUP3S	T	1/33	6EUP6S	T	1/33
size(mm)	L	E (min)																														
110	3m	3.2																														
110	6m	3.2																														
160	3m	4.1																														
160	6m	4.1																														
Code	Col	Pk/bk																														
4EUP3S	T	1/67																														
4EUP6S	T	1/67																														
6EUP3S	T	1/33																														
6EUP6S	T	1/33																														
COUPLER DOUBLE SOCKET 	<p>With central stop</p> <table border="1"> <thead> <tr> <th>size(mm)</th> <th>L</th> <th>Z</th> </tr> </thead> <tbody> <tr> <td>82</td> <td>136</td> <td>3.5</td> </tr> <tr> <td>110</td> <td>122</td> <td>2</td> </tr> <tr> <td>160</td> <td>154</td> <td>4</td> </tr> </tbody> </table>	size(mm)	L	Z	82	136	3.5	110	122	2	160	154	4	<table border="1"> <thead> <tr> <th>Code</th> <th>Col</th> <th>Pk/bx</th> </tr> </thead> <tbody> <tr> <td>3D20D</td> <td>T</td> <td>10/60</td> </tr> <tr> <td>4D20D</td> <td>T</td> <td>5/45</td> </tr> <tr> <td>6D20D</td> <td>T</td> <td>5/15</td> </tr> </tbody> </table>	Code	Col	Pk/bx	3D20D	T	10/60	4D20D	T	5/45	6D20D	T	5/15						
size(mm)	L	Z																														
82	136	3.5																														
110	122	2																														
160	154	4																														
Code	Col	Pk/bx																														
3D20D	T	10/60																														
4D20D	T	5/45																														
6D20D	T	5/15																														
SLIP COUPLER 	<p>For inserting new fittings into existing pipework (e.g. refurbishment or repair)</p> <table border="1"> <thead> <tr> <th>size(mm)</th> <th>L</th> </tr> </thead> <tbody> <tr> <td>110</td> <td>122</td> </tr> <tr> <td>160</td> <td>154</td> </tr> </tbody> </table>	size(mm)	L	110	122	160	154	<table border="1"> <thead> <tr> <th>Code</th> <th>Col</th> <th>Pk/bx</th> </tr> </thead> <tbody> <tr> <td>4D20DSC</td> <td>T</td> <td>5/45</td> </tr> <tr> <td>6D20DSC</td> <td>T</td> <td>1/15</td> </tr> </tbody> </table>	Code	Col	Pk/bx	4D20DSC	T	5/45	6D20DSC	T	1/15															
size(mm)	L																															
110	122																															
160	154																															
Code	Col	Pk/bx																														
4D20DSC	T	5/45																														
6D20DSC	T	1/15																														
PIPE END SOCKET 	<table border="1"> <thead> <tr> <th>size(mm)</th> <th>L1</th> <th>L2</th> <th>Z</th> </tr> </thead> <tbody> <tr> <td>110</td> <td>121</td> <td>48</td> <td>3</td> </tr> <tr> <td>160</td> <td>167</td> <td>68</td> <td>3</td> </tr> </tbody> </table>	size(mm)	L1	L2	Z	110	121	48	3	160	167	68	3	<table border="1"> <thead> <tr> <th>Code</th> <th>Col</th> <th>Pk/bx</th> </tr> </thead> <tbody> <tr> <td>4D69</td> <td>T</td> <td>5/40</td> </tr> <tr> <td>6D69</td> <td>T</td> <td>1/15</td> </tr> </tbody> </table>	Code	Col	Pk/bx	4D69	T	5/40	6D69	T	1/15									
size(mm)	L1	L2	Z																													
110	121	48	3																													
160	167	68	3																													
Code	Col	Pk/bx																														
4D69	T	5/40																														
6D69	T	1/15																														

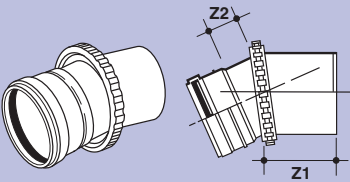
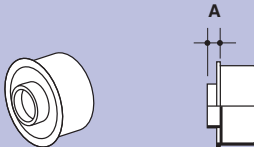
<p>SHORT RADIUS BEND DOUBLE SOCKET</p>	<p>To change pipe direction: 87½°, 45°, 30° and 15° as standard</p> <table border="1"> <thead> <tr> <th>size(mm)</th> <th>angle°</th> <th>L</th> <th>Z</th> <th></th> </tr> </thead> <tbody> <tr> <td>82</td> <td>87½</td> <td>142</td> <td>70</td> <td></td> </tr> <tr> <td>82</td> <td>45</td> <td>97</td> <td>25</td> <td></td> </tr> <tr> <td>♥ 110</td> <td>87½</td> <td>120</td> <td>70</td> <td></td> </tr> <tr> <td>♥ 110</td> <td>87½</td> <td>150</td> <td>87</td> <td>(swept)</td> </tr> <tr> <td>♥ 110</td> <td>45</td> <td>87</td> <td>37</td> <td></td> </tr> <tr> <td>♥ 110</td> <td>30</td> <td>83</td> <td>27</td> <td></td> </tr> <tr> <td>♥ 110</td> <td>15</td> <td>76</td> <td>20</td> <td></td> </tr> <tr> <td>♥ 160</td> <td>87½</td> <td>202</td> <td>124</td> <td></td> </tr> <tr> <td>♥ 160</td> <td>45</td> <td>122</td> <td>49</td> <td></td> </tr> <tr> <td>♥ 160</td> <td>30</td> <td>114</td> <td>40</td> <td></td> </tr> <tr> <td>♥ 160</td> <td>15</td> <td>101</td> <td>28</td> <td></td> </tr> </tbody> </table>	size(mm)	angle°	L	Z		82	87½	142	70		82	45	97	25		♥ 110	87½	120	70		♥ 110	87½	150	87	(swept)	♥ 110	45	87	37		♥ 110	30	83	27		♥ 110	15	76	20		♥ 160	87½	202	124		♥ 160	45	122	49		♥ 160	30	114	40		♥ 160	15	101	28		<table border="1"> <thead> <tr> <th>Code</th> <th>Col</th> <th>Pk/bx</th> </tr> </thead> <tbody> <tr> <td>3D23D</td> <td>T</td> <td>1/30</td> </tr> <tr> <td>3D25D</td> <td>T</td> <td>5/35</td> </tr> <tr> <td>4D23D</td> <td>T</td> <td>5/25</td> </tr> <tr> <td>4D23DX</td> <td>T</td> <td>4/18</td> </tr> <tr> <td>4D25D</td> <td>T</td> <td>5/30</td> </tr> <tr> <td>4D27D</td> <td>T</td> <td>5/35</td> </tr> <tr> <td>4D29D</td> <td>T</td> <td>5/35</td> </tr> <tr> <td>6D23D</td> <td>T</td> <td>1/4</td> </tr> <tr> <td>6D25D</td> <td>T</td> <td>5/10</td> </tr> <tr> <td>6D27D</td> <td>T</td> <td>1/10</td> </tr> <tr> <td>6D29D</td> <td>T</td> <td>1/12</td> </tr> </tbody> </table>	Code	Col	Pk/bx	3D23D	T	1/30	3D25D	T	5/35	4D23D	T	5/25	4D23DX	T	4/18	4D25D	T	5/30	4D27D	T	5/35	4D29D	T	5/35	6D23D	T	1/4	6D25D	T	5/10	6D27D	T	1/10	6D29D	T	1/12
size(mm)	angle°	L	Z																																																																																															
82	87½	142	70																																																																																															
82	45	97	25																																																																																															
♥ 110	87½	120	70																																																																																															
♥ 110	87½	150	87	(swept)																																																																																														
♥ 110	45	87	37																																																																																															
♥ 110	30	83	27																																																																																															
♥ 110	15	76	20																																																																																															
♥ 160	87½	202	124																																																																																															
♥ 160	45	122	49																																																																																															
♥ 160	30	114	40																																																																																															
♥ 160	15	101	28																																																																																															
Code	Col	Pk/bx																																																																																																
3D23D	T	1/30																																																																																																
3D25D	T	5/35																																																																																																
4D23D	T	5/25																																																																																																
4D23DX	T	4/18																																																																																																
4D25D	T	5/30																																																																																																
4D27D	T	5/35																																																																																																
4D29D	T	5/35																																																																																																
6D23D	T	1/4																																																																																																
6D25D	T	5/10																																																																																																
6D27D	T	1/10																																																																																																
6D29D	T	1/12																																																																																																
<p>SHORT RADIUS BEND SINGLE SOCKET</p>	<p>To change pipe direction: 87½°, 45°, 30° and 15° as standard</p> <table border="1"> <thead> <tr> <th>size(mm)</th> <th>angle°</th> <th>L1</th> <th>L2</th> <th>Z1</th> <th>Z2</th> <th></th> </tr> </thead> <tbody> <tr> <td>♥ 110</td> <td>87½</td> <td>117</td> <td>119</td> <td>59</td> <td>69</td> <td></td> </tr> <tr> <td>♥ 110</td> <td>45</td> <td>85</td> <td>89</td> <td>27</td> <td>39</td> <td></td> </tr> <tr> <td>♥ 110</td> <td>30</td> <td>78</td> <td>86</td> <td>17</td> <td>29</td> <td></td> </tr> <tr> <td>♥ 110</td> <td>15</td> <td>71</td> <td>79</td> <td>9</td> <td>22</td> <td></td> </tr> <tr> <td>♥ 160</td> <td>87½</td> <td>164</td> <td>166</td> <td>84</td> <td>100</td> <td></td> </tr> <tr> <td>♥ 160</td> <td>45</td> <td>117</td> <td>116</td> <td>37</td> <td>50</td> <td></td> </tr> <tr> <td>♥ 160</td> <td>30</td> <td>107</td> <td>112</td> <td>25</td> <td>40</td> <td></td> </tr> <tr> <td>♥ 160</td> <td>15</td> <td>96</td> <td>100</td> <td>14</td> <td>28</td> <td></td> </tr> </tbody> </table>	size(mm)	angle°	L1	L2	Z1	Z2		♥ 110	87½	117	119	59	69		♥ 110	45	85	89	27	39		♥ 110	30	78	86	17	29		♥ 110	15	71	79	9	22		♥ 160	87½	164	166	84	100		♥ 160	45	117	116	37	50		♥ 160	30	107	112	25	40		♥ 160	15	96	100	14	28		<table border="1"> <thead> <tr> <th>Code</th> <th>Col</th> <th>Pk/bx</th> </tr> </thead> <tbody> <tr> <td>4D23</td> <td>T</td> <td>5/25</td> </tr> <tr> <td>4D25</td> <td>T</td> <td>5/35</td> </tr> <tr> <td>4D27</td> <td>T</td> <td>5/40</td> </tr> <tr> <td>4D29</td> <td>T</td> <td>5/40</td> </tr> <tr> <td>6D23</td> <td>T</td> <td>5/10</td> </tr> <tr> <td>6D25</td> <td>T</td> <td>5/10</td> </tr> <tr> <td>6D27</td> <td>T</td> <td>4/12</td> </tr> <tr> <td>6D29</td> <td>T</td> <td>1/13</td> </tr> </tbody> </table>	Code	Col	Pk/bx	4D23	T	5/25	4D25	T	5/35	4D27	T	5/40	4D29	T	5/40	6D23	T	5/10	6D25	T	5/10	6D27	T	4/12	6D29	T	1/13						
size(mm)	angle°	L1	L2	Z1	Z2																																																																																													
♥ 110	87½	117	119	59	69																																																																																													
♥ 110	45	85	89	27	39																																																																																													
♥ 110	30	78	86	17	29																																																																																													
♥ 110	15	71	79	9	22																																																																																													
♥ 160	87½	164	166	84	100																																																																																													
♥ 160	45	117	116	37	50																																																																																													
♥ 160	30	107	112	25	40																																																																																													
♥ 160	15	96	100	14	28																																																																																													
Code	Col	Pk/bx																																																																																																
4D23	T	5/25																																																																																																
4D25	T	5/35																																																																																																
4D27	T	5/40																																																																																																
4D29	T	5/40																																																																																																
6D23	T	5/10																																																																																																
6D25	T	5/10																																																																																																
6D27	T	4/12																																																																																																
6D29	T	1/13																																																																																																
<p>LONG RADIUS BENDS (PLAIN ENDED)</p>	<p>90° and 45° as standard</p> <table border="1"> <thead> <tr> <th>size(mm)</th> <th>angle°</th> <th>R</th> <th>Z</th> <th></th> </tr> </thead> <tbody> <tr> <td>♣ 110</td> <td>90</td> <td>455</td> <td>539</td> <td></td> </tr> <tr> <td>♣ 110</td> <td>45</td> <td>455</td> <td>368</td> <td></td> </tr> </tbody> </table>	size(mm)	angle°	R	Z		♣ 110	90	455	539		♣ 110	45	455	368		<table border="1"> <thead> <tr> <th>Code</th> <th>Col</th> <th>Pk/bx</th> </tr> </thead> <tbody> <tr> <td>4D22</td> <td>T</td> <td>1/50</td> </tr> <tr> <td>4D28</td> <td>T</td> <td>1/80</td> </tr> </tbody> </table>	Code	Col	Pk/bx	4D22	T	1/50	4D28	T	1/80																																																																								
size(mm)	angle°	R	Z																																																																																															
♣ 110	90	455	539																																																																																															
♣ 110	45	455	368																																																																																															
Code	Col	Pk/bx																																																																																																
4D22	T	1/50																																																																																																
4D28	T	1/80																																																																																																
<p>REST BEND SINGLE SOCKET</p>	<p>To change 110mm pipe direction at base of soil stack: 87½° as standard Satisfies recommendations of BS 5772: 1994</p> <table border="1"> <thead> <tr> <th>size(mm)</th> <th>angle°</th> <th>L</th> <th>R</th> <th>Z1</th> <th>Z2</th> <th></th> </tr> </thead> <tbody> <tr> <td>110</td> <td>87½</td> <td>230</td> <td>200</td> <td>245</td> <td>170</td> <td></td> </tr> </tbody> </table>	size(mm)	angle°	L	R	Z1	Z2		110	87½	230	200	245	170		<table border="1"> <thead> <tr> <th>Code</th> <th>Col</th> <th>Pk/bx</th> </tr> </thead> <tbody> <tr> <td>4D21</td> <td>T</td> <td>5/10</td> </tr> </tbody> </table>	Code	Col	Pk/bx	4D21	T	5/10																																																																												
size(mm)	angle°	L	R	Z1	Z2																																																																																													
110	87½	230	200	245	170																																																																																													
Code	Col	Pk/bx																																																																																																
4D21	T	5/10																																																																																																
<p>REST BEND DOUBLE SOCKET</p>	<p>To change 110mm pipe direction at base of soil stack: 87½° as standard Satisfies recommendations of BS 5772: 1994</p> <table border="1"> <thead> <tr> <th>size(mm)</th> <th>angle°</th> <th>L</th> <th>R</th> <th>Z1</th> <th>Z2</th> <th></th> </tr> </thead> <tbody> <tr> <td>110</td> <td>87½</td> <td>205</td> <td>200</td> <td>245</td> <td>170</td> <td></td> </tr> </tbody> </table>	size(mm)	angle°	L	R	Z1	Z2		110	87½	205	200	245	170		<table border="1"> <thead> <tr> <th>Code</th> <th>Col</th> <th>Pk/bx</th> </tr> </thead> <tbody> <tr> <td>4D21D</td> <td>T</td> <td>3/9</td> </tr> </tbody> </table>	Code	Col	Pk/bx	4D21D	T	3/9																																																																												
size(mm)	angle°	L	R	Z1	Z2																																																																																													
110	87½	205	200	245	170																																																																																													
Code	Col	Pk/bx																																																																																																
4D21D	T	3/9																																																																																																

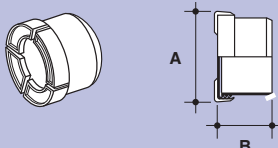
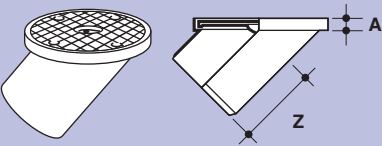
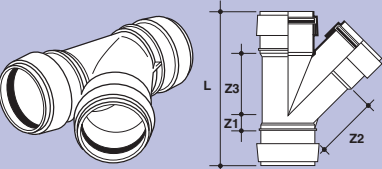
<p>VARIABLE BEND SINGLE SOCKET</p> 	<p>To change 110mm pipe direction by 0–25° Z dimensions are constant whichever angle is selected Any non-standard angle can be achieved if used in conjunction with a standard fitting</p> <table border="1"> <thead> <tr> <th>size(mm)</th> <th>angle°</th> <th>Z1</th> <th>Z2</th> </tr> </thead> <tbody> <tr> <td>110</td> <td>0–25</td> <td>86</td> <td>45</td> </tr> </tbody> </table>	size(mm)	angle°	Z1	Z2	110	0–25	86	45	<table border="1"> <thead> <tr> <th>Code</th> <th>Col</th> <th>Pk/bx</th> </tr> </thead> <tbody> <tr> <td>4DV40</td> <td>T</td> <td>5/25</td> </tr> </tbody> </table>	Code	Col	Pk/bx	4DV40	T	5/25				
size(mm)	angle°	Z1	Z2																	
110	0–25	86	45																	
Code	Col	Pk/bx																		
4DV40	T	5/25																		
<p>SOCKET PLUG</p> 	<p>To blank off any ring seal socket</p> <table border="1"> <thead> <tr> <th>size(mm)</th> <th>A</th> </tr> </thead> <tbody> <tr> <td>110</td> <td>18</td> </tr> <tr> <td>160</td> <td>16</td> </tr> </tbody> </table>	size(mm)	A	110	18	160	16	<table border="1"> <thead> <tr> <th>Code</th> <th>Col</th> <th>Pk/bx</th> </tr> </thead> <tbody> <tr> <td>4D68</td> <td>T</td> <td>6/54</td> </tr> <tr> <td>6D68</td> <td>T</td> <td>1/30</td> </tr> </tbody> </table>	Code	Col	Pk/bx	4D68	T	6/54	6D68	T	1/30			
size(mm)	A																			
110	18																			
160	16																			
Code	Col	Pk/bx																		
4D68	T	6/54																		
6D68	T	1/30																		
<p>TEMPORARY SITE CAP</p> 	<p>For temporary capping of system Versions for external and internal use</p> <table border="1"> <thead> <tr> <th>size(mm)</th> <th>A</th> </tr> </thead> <tbody> <tr> <td>110</td> <td>30</td> </tr> </tbody> </table>	size(mm)	A	110	30	<table border="1"> <thead> <tr> <th>Code</th> <th>Col</th> <th>Pk/bx</th> </tr> </thead> <tbody> <tr> <td>4D65</td> <td>R</td> <td>250</td> </tr> </tbody> </table>	Code	Col	Pk/bx	4D65	R	250								
size(mm)	A																			
110	30																			
Code	Col	Pk/bx																		
4D65	R	250																		
<p>ACCESS CAP</p> 	<p>To allow full bore access to 82mm, 110mm or 160mm pipework for inspection or rodding</p> <table border="1"> <thead> <tr> <th>size(mm)</th> <th>A</th> <th>B</th> </tr> </thead> <tbody> <tr> <td>110</td> <td>126</td> <td>115</td> </tr> <tr> <td>160</td> <td>188</td> <td>107</td> </tr> </tbody> </table>	size(mm)	A	B	110	126	115	160	188	107	<table border="1"> <thead> <tr> <th>Code</th> <th>Col</th> <th>Pk/bx</th> </tr> </thead> <tbody> <tr> <td>4D64</td> <td>T</td> <td>5/50</td> </tr> <tr> <td>6D64</td> <td>T</td> <td>1/15</td> </tr> </tbody> </table>	Code	Col	Pk/bx	4D64	T	5/50	6D64	T	1/15
size(mm)	A	B																		
110	126	115																		
160	188	107																		
Code	Col	Pk/bx																		
4D64	T	5/50																		
6D64	T	1/15																		
<p>RODDING EYE</p> 	<p><i>Material: Aluminium</i> Elliptical rodding eye with 110mm pipe size spigot Access aperture size: 118x90mm</p> <table border="1"> <thead> <tr> <th>size(mm)</th> <th>A</th> <th>Z</th> </tr> </thead> <tbody> <tr> <td>110</td> <td>13</td> <td>95</td> </tr> </tbody> </table>	size(mm)	A	Z	110	13	95	<table border="1"> <thead> <tr> <th>Code</th> <th>Col</th> <th>Pk/bx</th> </tr> </thead> <tbody> <tr> <td>4DRE</td> <td>self</td> <td>5/25</td> </tr> </tbody> </table>	Code	Col	Pk/bx	4DRE	self	5/25						
size(mm)	A	Z																		
110	13	95																		
Code	Col	Pk/bx																		
4DRE	self	5/25																		
<p>SINGLE EQUAL JUNCTION</p> 	<p>To join 82mm branch pipe to 82mm main pipe at an angle: 45° as standard</p> <table border="1"> <thead> <tr> <th>size(mm)</th> <th>angle°</th> <th>L</th> <th>Z1</th> <th>Z2</th> <th>Z3</th> </tr> </thead> <tbody> <tr> <td>82</td> <td>45</td> <td>265</td> <td>19</td> <td>108</td> <td>102</td> </tr> </tbody> </table>	size(mm)	angle°	L	Z1	Z2	Z3	82	45	265	19	108	102	<table border="1"> <thead> <tr> <th>Code</th> <th>Col</th> <th>Pk/bx</th> </tr> </thead> <tbody> <tr> <td>3D33D</td> <td>T</td> <td>1/20</td> </tr> </tbody> </table>	Code	Col	Pk/bx	3D33D	T	1/20
size(mm)	angle°	L	Z1	Z2	Z3															
82	45	265	19	108	102															
Code	Col	Pk/bx																		
3D33D	T	1/20																		

SINGLE EQUAL JUNCTION (ALL EQUAL SOCKETS)

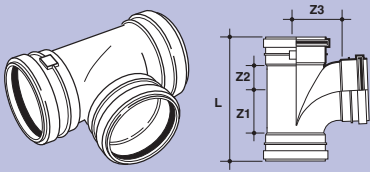

To join 110mm or 160mm branch pipe to 110mm or 160mm main pipe at an angle:
(110mm) 87 $\frac{1}{2}$ ° and 45° as standard
(160mm) 45° as standard

size(mm)	angle°	L	Z1	Z2	Z3
110	87 $\frac{1}{2}$	268	87	57	87
160	87 $\frac{1}{2}$	338	95	99	99

Code	Col	Pk/bx
4D30D	T	5/15
6D30D	T	5

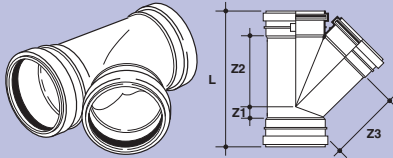

size(mm)	angle°	L	Z1	Z2	Z3
110	45	294	37	137	137
160	45	399	52	203	203

Code	Col	Pk/bx
4D33D	T	4/12
6D33D	T	1/4

EQUAL SOCKETS PLUS SPIGOT OUTLET

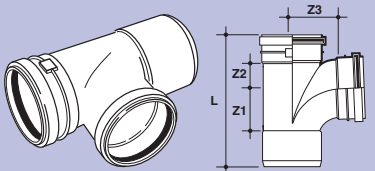

To join 110mm or 160mm branch pipe to 110mm or 160mm main pipe at an angle:
(110mm) 87 $\frac{1}{2}$ ° and 45° as standard
(160mm) 45° as standard

size(mm)	angle°	L	Z1	Z2	Z3
110	87 $\frac{1}{2}$	239	59	69	69

Code	Col	Pk/bx
4D30	T	5/15

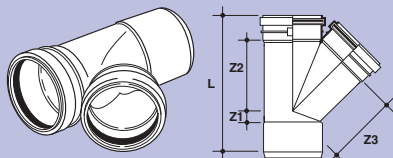

size(mm)	angle°	L	Z1	Z2	Z3
110	45	278	27	143	143
160	45	397	38	205	205

Code	Col	Pk/bx
4D33	T	5/15
6D33	T	1/4

SINGLE UNEQUAL JUNCTION (ALL SOCKET)

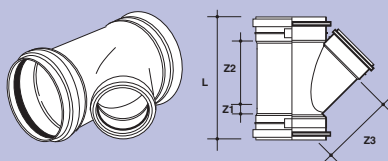

To join 110mm branch pipe to 160mm main pipe at an angle: 45° and 87 $\frac{1}{2}$ ° as standard

size(mm)	angle°	L	Z1	Z2	Z3
160/110	45	334	19	169	176
160/110	87 $\frac{1}{2}$	289	70	75	95

Code	Col	Pk/bx
64D33D	T	2/6
64D30D	T	1/8

SPIGOT OUTLET

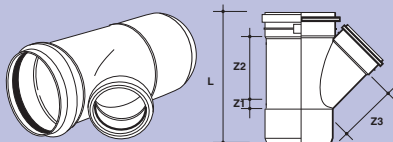

To join 110mm branch pipe to 160mm main pipe at an angle:
45° as standard

size(mm)	angle°	L	Z1	Z2	Z3
160/110	45	326	2	168	176

Code	Col	Pk/bx
64D33	T	1/7

<p>GULLY TRAP</p>	<p><i>Material: Polypropylene</i> To obtain 'P' trap, add 45° bend</p> <table border="1"> <thead> <tr> <th>size(mm)</th> <th>A</th> <th>B</th> <th>Z1</th> <th>Z2</th> </tr> </thead> <tbody> <tr> <td>110</td> <td>50</td> <td>190</td> <td>120</td> <td>210</td> </tr> </tbody> </table>	size(mm)	A	B	Z1	Z2	110	50	190	120	210	<table border="1"> <thead> <tr> <th>Code</th> <th>Col</th> <th>Pk/bx</th> </tr> </thead> <tbody> <tr> <td>4DG90</td> <td>T</td> <td>4/12</td> </tr> </tbody> </table>	Code	Col	Pk/bx	4DG90	T	4/12		
size(mm)	A	B	Z1	Z2																
110	50	190	120	210																
Code	Col	Pk/bx																		
4DG90	T	4/12																		
<p>'P' TRAP</p>	<p><i>Material: PVC-u</i> To obtain 'Q' or 'S' trap, add 45° or 87 1/2° bend</p> <table border="1"> <thead> <tr> <th>size(mm)</th> <th>A</th> <th>B</th> <th>Z1</th> <th>Z2</th> </tr> </thead> <tbody> <tr> <td>110</td> <td>104</td> <td>193</td> <td>92</td> <td>265</td> </tr> </tbody> </table>	size(mm)	A	B	Z1	Z2	110	104	193	92	265	<table border="1"> <thead> <tr> <th>Code</th> <th>Col</th> <th>Pk/bx</th> </tr> </thead> <tbody> <tr> <td>4DG91</td> <td>T</td> <td>4/8</td> </tr> </tbody> </table>	Code	Col	Pk/bx	4DG91	T	4/8		
size(mm)	A	B	Z1	Z2																
110	104	193	92	265																
Code	Col	Pk/bx																		
4DG91	T	4/8																		
<p>SQUARE HOPPER HEAD</p>	<p><i>Material: PVC-u and Polypropylene</i> Spigot outlet may be cut off to reveal socket which can accept solvent-welded pipe as extended spigot Terracotta body with Black grid</p> <table border="1"> <thead> <tr> <th>size(mm)</th> <th>L</th> <th>Z</th> </tr> </thead> <tbody> <tr> <td>110</td> <td>203</td> <td>105</td> </tr> </tbody> </table>	size(mm)	L	Z	110	203	105	<table border="1"> <thead> <tr> <th>Code</th> <th>Col</th> <th>Pk/bx</th> </tr> </thead> <tbody> <tr> <td>4DG92</td> <td>T</td> <td>5/15</td> </tr> </tbody> </table>	Code	Col	Pk/bx	4DG92	T	5/15						
size(mm)	L	Z																		
110	203	105																		
Code	Col	Pk/bx																		
4DG92	T	5/15																		
<p>RECTANGULAR HOPPER HEAD</p>	<p><i>Material: PVC-u and Polypropylene</i> Back inlet plate incorporates two easily removable discs to create apertures for insertion of 40mm waste pipes Terracotta body with Black grid</p> <table border="1"> <thead> <tr> <th>size(mm)</th> <th>A</th> <th>L</th> <th>Z</th> </tr> </thead> <tbody> <tr> <td>110</td> <td>85</td> <td>203</td> <td>105</td> </tr> </tbody> </table>	size(mm)	A	L	Z	110	85	203	105	<table border="1"> <thead> <tr> <th>Code</th> <th>Col</th> <th>Pk/bx</th> </tr> </thead> <tbody> <tr> <td>4DG93</td> <td>T</td> <td>4/12</td> </tr> </tbody> </table>	Code	Col	Pk/bx	4DG93	T	4/12				
size(mm)	A	L	Z																	
110	85	203	105																	
Code	Col	Pk/bx																		
4DG93	T	4/12																		
<p>CIRCULAR GULLY</p>	<p><i>Material: PVC-u</i> Incorporates plugged horizontal pipe entries: 2x110mm spigots, 1x110mm ring seal socket and 1x68mm rainwater pipe socket Spigot outlet may be cut off to reveal socket which can accept solvent-welded pipe as extended spigot</p> <table border="1"> <thead> <tr> <th>size(mm)</th> <th>A</th> <th>B</th> <th>L</th> <th>Z</th> </tr> </thead> <tbody> <tr> <td>110</td> <td>95</td> <td>67</td> <td>242</td> <td>70</td> </tr> </tbody> </table>	size(mm)	A	B	L	Z	110	95	67	242	70	<table border="1"> <thead> <tr> <th>Code</th> <th>Col</th> <th>Pk/bx</th> </tr> </thead> <tbody> <tr> <td>4DG80</td> <td>T</td> <td>2/4</td> </tr> </tbody> </table>	Code	Col	Pk/bx	4DG80	T	2/4		
size(mm)	A	B	L	Z																
110	95	67	242	70																
Code	Col	Pk/bx																		
4DG80	T	2/4																		
<p>EXTENSION PIECE</p>	<p>To extend upper aperture of 4DG80 Circular Gully to surface level OR to lower horizontal pipe entries beneath surface level Requires mastic sealant for forming airtight/watertight seal</p> <table border="1"> <thead> <tr> <th>A</th> <th>L</th> </tr> </thead> <tbody> <tr> <td>213</td> <td>150</td> </tr> </tbody> </table>	A	L	213	150	<table border="1"> <thead> <tr> <th>Code</th> <th>Col</th> <th>Pk/bx</th> </tr> </thead> <tbody> <tr> <td>4DG81</td> <td>T</td> <td>1/10</td> </tr> </tbody> </table>	Code	Col	Pk/bx	4DG81	T	1/10								
A	L																			
213	150																			
Code	Col	Pk/bx																		
4DG81	T	1/10																		
<p>BOTTLE GULLY WITH ROUND COVER</p>	<p><i>Material: PVC-u and Polypropylene</i> Removable dip tube provides 50mm deep trap Incorporates 110mm back inlet connection Terracotta body with Black cover</p> <table border="1"> <thead> <tr> <th>size(mm)</th> <th>A</th> <th>D</th> <th>E</th> <th>F</th> <th>G</th> </tr> </thead> <tbody> <tr> <td>110</td> <td>213</td> <td>150</td> <td>154</td> <td>304</td> <td>190</td> </tr> </tbody> </table>	size(mm)	A	D	E	F	G	110	213	150	154	304	190	<table border="1"> <thead> <tr> <th>Code</th> <th>Col</th> <th>Pk/bx</th> </tr> </thead> <tbody> <tr> <td>4DG97</td> <td>T</td> <td>4</td> </tr> </tbody> </table>	Code	Col	Pk/bx	4DG97	T	4
size(mm)	A	D	E	F	G															
110	213	150	154	304	190															
Code	Col	Pk/bx																		
4DG97	T	4																		

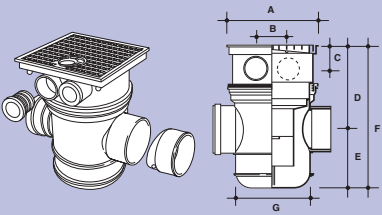
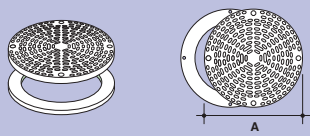
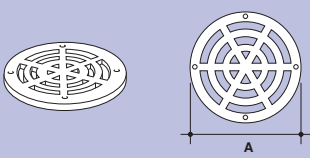
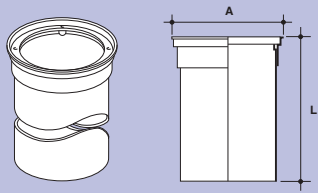
<p>BOTTLE GULLY WITH SQUARE COVER</p> 	<p><i>Material:</i> PVC-u and Polypropylene Removable dip tube provides 50mm deep trap Incorporates 2 x waste back inlet connections. Can also accept up to 6 different pipes either direct or via adaptors Terracotta body with Black cover</p> <table border="1"> <thead> <tr> <th>size(mm)</th> <th>A</th> <th>B</th> <th>C</th> <th>D</th> <th>E</th> <th>F</th> <th>G</th> <th>Code</th> <th>Col</th> <th>Pk/bx</th> </tr> </thead> <tbody> <tr> <td>110</td> <td>232</td> <td>76</td> <td>60</td> <td>212</td> <td>154</td> <td>366</td> <td>190</td> <td>4DG89</td> <td>T</td> <td>4</td> </tr> </tbody> </table>	size(mm)	A	B	C	D	E	F	G	Code	Col	Pk/bx	110	232	76	60	212	154	366	190	4DG89	T	4	
size(mm)	A	B	C	D	E	F	G	Code	Col	Pk/bx														
110	232	76	60	212	154	366	190	4DG89	T	4														
<p>SEALED COVER</p> 	<p>To cap 4DG80 Circular Gully or 4DG81 Extension Piece</p> <table border="1"> <thead> <tr> <th>A</th> <th>Code</th> <th>Col</th> <th>Pk/bx</th> </tr> </thead> <tbody> <tr> <td>211</td> <td>4DG82</td> <td>B</td> <td>1/30</td> </tr> </tbody> </table>	A	Code	Col	Pk/bx	211	4DG82	B	1/30															
A	Code	Col	Pk/bx																					
211	4DG82	B	1/30																					
<p>CIRCULAR GRATING</p> 	<p>To provide an open grating for surface water drainage for 4DG80 Circular Gully or 4DG81 Extension Piece A/so: spare grating for 4DG97 Bottle Gully</p> <table border="1"> <thead> <tr> <th>A</th> <th>Code</th> <th>Col</th> <th>Pk/bx</th> </tr> </thead> <tbody> <tr> <td>211</td> <td>4DG83</td> <td>B</td> <td>1/30</td> </tr> </tbody> </table>	A	Code	Col	Pk/bx	211	4DG83	B	1/30															
A	Code	Col	Pk/bx																					
211	4DG83	B	1/30																					
<p>RAISING PIECE</p> 	<p>To extend upper aperture of 4DG97 Bottle Gully to surface level OR to lower horizontal pipe entries beneath surface level</p> <table border="1"> <thead> <tr> <th>size(mm)</th> <th>A</th> <th>L</th> <th>Code</th> <th>Col</th> <th>Pk/bx</th> </tr> </thead> <tbody> <tr> <td>200</td> <td>213</td> <td>470</td> <td>4DG96</td> <td>T</td> <td>3</td> </tr> </tbody> </table>	size(mm)	A	L	Code	Col	Pk/bx	200	213	470	4DG96	T	3											
size(mm)	A	L	Code	Col	Pk/bx																			
200	213	470	4DG96	T	3																			
<p>SQUARE HOPPER HEAD GRID</p>	<p><i>Material:</i> Polypropylene Spare grid for 4DG92 Hopper Head</p> <table border="1"> <thead> <tr> <th>Code</th> <th>Col</th> <th>Pk/bx</th> </tr> </thead> <tbody> <tr> <td>4DG92G</td> <td>B</td> <td>1/100</td> </tr> </tbody> </table>	Code	Col	Pk/bx	4DG92G	B	1/100																	
Code	Col	Pk/bx																						
4DG92G	B	1/100																						
<p>SQUARE SEALED COVER</p>	<p><i>Material:</i> Polypropylene Converts 4DG92 Square Hopper Head from open grid to sealed cover</p> <table border="1"> <thead> <tr> <th>Code</th> <th>Col</th> <th>Pk/bx</th> </tr> </thead> <tbody> <tr> <td>4DG92GS</td> <td>B</td> <td>1/100</td> </tr> </tbody> </table>	Code	Col	Pk/bx	4DG92GS	B	1/100																	
Code	Col	Pk/bx																						
4DG92GS	B	1/100																						

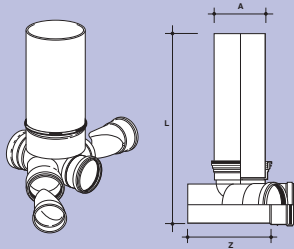
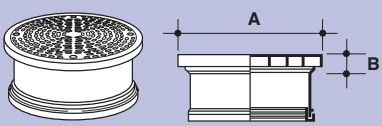
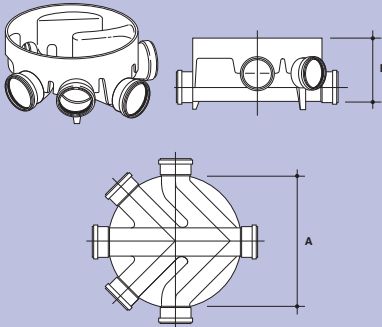
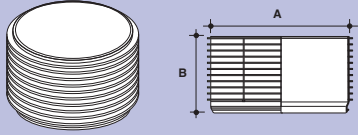
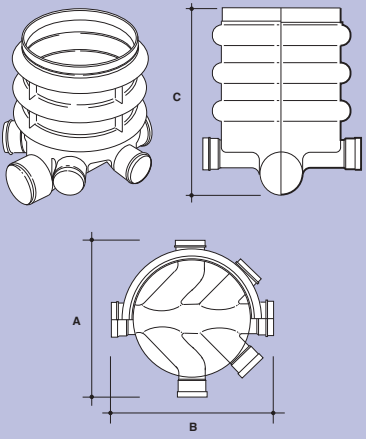
<p>SHALLOW INSPECTION CHAMBER</p> 	<p>To allow inspection of drainage system Supplied with 2 plugs for unused entries 200mm socket has angular tolerance of $\pm 7^\circ$ allowing up to 14° adjustment to accommodate pipe variation and ground fall 9163.4 Access Door may be fitted to the lower opening to achieve double seal Access aperture size: 162x100mm</p> <table border="1"> <thead> <tr> <th>size(mm)</th> <th>A</th> <th>L</th> <th>Z</th> </tr> </thead> <tbody> <tr> <td>110</td> <td>200</td> <td>586</td> <td>261</td> </tr> </tbody> </table>	size(mm)	A	L	Z	110	200	586	261	<table border="1"> <thead> <tr> <th>Code</th> <th>Col</th> <th>Pk/bx</th> </tr> </thead> <tbody> <tr> <td>4DI600</td> <td>T</td> <td>2</td> </tr> </tbody> </table>	Code	Col	Pk/bx	4DI600	T	2
size(mm)	A	L	Z													
110	200	586	261													
Code	Col	Pk/bx														
4DI600	T	2														
<p>SEALED COVER AND FRAME</p> 	<p>To cap 4DI600 Shallow Inspection Chamber Ring seal joint to shaft</p> <table border="1"> <thead> <tr> <th>size(mm)</th> <th>A</th> <th>B</th> </tr> </thead> <tbody> <tr> <td>110</td> <td>211</td> <td>43</td> </tr> </tbody> </table>	size(mm)	A	B	110	211	43	<table border="1"> <thead> <tr> <th>Code</th> <th>Col</th> <th>Pk/bx</th> </tr> </thead> <tbody> <tr> <td>4DIFC1</td> <td>B</td> <td>4/12</td> </tr> </tbody> </table>	Code	Col	Pk/bx	4DIFC1	B	4/12		
size(mm)	A	B														
110	211	43														
Code	Col	Pk/bx														
4DIFC1	B	4/12														
<p>INSPECTION CHAMBER BASE (470MM DIAMETER)</p> 	<p><i>Material: Polypropylene</i> To allow inspection of drainage system Incorporating 110mm main channel and 4 x 110mm branch inlets Supplied with 4 x blanking plugs</p> <table border="1"> <thead> <tr> <th>size(mm)</th> <th>A</th> <th>B</th> </tr> </thead> <tbody> <tr> <td>110</td> <td>470</td> <td>240</td> </tr> </tbody> </table>	size(mm)	A	B	110	470	240	<table border="1"> <thead> <tr> <th>Code</th> <th>Col</th> <th>Pk/bx</th> </tr> </thead> <tbody> <tr> <td>4DI240B</td> <td>T</td> <td>1</td> </tr> </tbody> </table>	Code	Col	Pk/bx	4DI240B	T	1		
size(mm)	A	B														
110	470	240														
Code	Col	Pk/bx														
4DI240B	T	1														
<p>RAISING PIECE</p> 	<p><i>Material: Polypropylene</i> To extend height of Marscar Access Bowl or Inspection Chamber Base (4DI240B) to surface level</p> <table border="1"> <thead> <tr> <th>A</th> <th>B</th> </tr> </thead> <tbody> <tr> <td>470</td> <td>235</td> </tr> </tbody> </table>	A	B	470	235	<table border="1"> <thead> <tr> <th>Code</th> <th>Col</th> <th>Pk/bx</th> </tr> </thead> <tbody> <tr> <td>4DI235R</td> <td>T</td> <td>1</td> </tr> </tbody> </table>	Code	Col	Pk/bx	4DI235R	T	1				
A	B															
470	235															
Code	Col	Pk/bx														
4DI235R	T	1														
<p>UNEQUAL INSPECTION CHAMBER BASE (475MM DIAMETER)</p> 	<p><i>Material: Polyethylene</i> To allow inspection of drainage system Incorporating 160mm main channel and 4 x 110mm branch inlets Supplied with 4 x 110mm seals</p> <table border="1"> <thead> <tr> <th>size(mm)</th> <th>A</th> <th>B</th> <th>C</th> </tr> </thead> <tbody> <tr> <td>160/110</td> <td>630</td> <td>685</td> <td>710</td> </tr> </tbody> </table>	size(mm)	A	B	C	160/110	630	685	710	<table border="1"> <thead> <tr> <th>Code</th> <th>Col</th> <th>Pk/bx</th> </tr> </thead> <tbody> <tr> <td>6DI750</td> <td>T</td> <td>18</td> </tr> </tbody> </table>	Code	Col	Pk/bx	6DI750	T	18
size(mm)	A	B	C													
160/110	630	685	710													
Code	Col	Pk/bx														
6DI750	T	18														

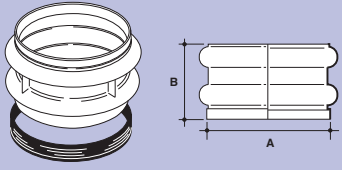
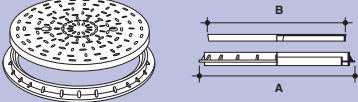
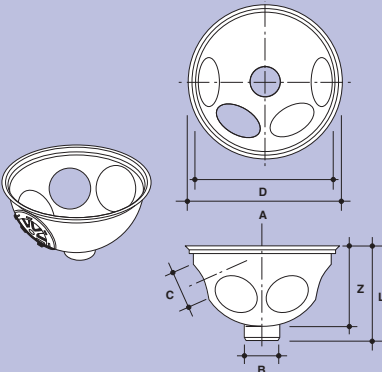
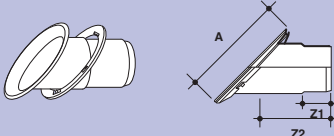
<p>INSPECTION CHAMBER EXTENSION PIECE (470MM DIAMETER)</p> 	<p><i>Material:</i> Polyethylene To extend upper aperture of 6DI750 Unequal Inspection Chamber Base to surface level Maximum depth 1 metre Supplied with fitted elastomeric seal</p> <table border="1" data-bbox="534 392 1053 481"> <thead> <tr> <th>A</th> <th>B</th> </tr> </thead> <tbody> <tr> <td>470</td> <td>235</td> </tr> </tbody> </table>	A	B	470	235	<table border="1" data-bbox="1093 392 1492 481"> <thead> <tr> <th>Code</th> <th>Col</th> <th>Pk/bx</th> </tr> </thead> <tbody> <tr> <td>6DI250</td> <td>T</td> <td>1</td> </tr> </tbody> </table>	Code	Col	Pk/bx	6DI250	T	1										
A	B																					
470	235																					
Code	Col	Pk/bx																				
6DI250	T	1																				
<p>COVER AND FRAME</p> 	<p><i>Material:</i> Cast Iron cover with Polypropylene frame BS EN 124: 1994 – Group 1, Class A15 (formerly BS497: 1976 Class C)</p> <table border="1" data-bbox="534 660 1053 750"> <thead> <tr> <th>A</th> <th>B</th> </tr> </thead> <tbody> <tr> <td>579</td> <td>454</td> </tr> </tbody> </table> <p><i>Material:</i> Polypropylene cover and frame BS EN 124: 1994 – Group 1, Class A15 (formerly BS497: 1976 Class C+) For domestic drive-ways accessible to vehicles up to one tonne maximum wheel load</p> <table border="1" data-bbox="534 884 1053 974"> <thead> <tr> <th>A</th> <th>B</th> </tr> </thead> <tbody> <tr> <td>579</td> <td>454</td> </tr> </tbody> </table>	A	B	579	454	A	B	579	454	<table border="1" data-bbox="1093 660 1492 750"> <thead> <tr> <th>Code</th> <th>Col</th> <th>Pk/bx</th> </tr> </thead> <tbody> <tr> <td>4DIFC3</td> <td>B</td> <td>1</td> </tr> </tbody> </table> <table border="1" data-bbox="1093 884 1492 974"> <thead> <tr> <th>Code</th> <th>Col</th> <th>Pk/bx</th> </tr> </thead> <tbody> <tr> <td>4DIFC4</td> <td>B</td> <td>1</td> </tr> </tbody> </table>	Code	Col	Pk/bx	4DIFC3	B	1	Code	Col	Pk/bx	4DIFC4	B	1
A	B																					
579	454																					
A	B																					
579	454																					
Code	Col	Pk/bx																				
4DIFC3	B	1																				
Code	Col	Pk/bx																				
4DIFC4	B	1																				
<p>MARSCAR ACCESS BOWL</p> 	<p><i>Material:</i> UPVC Unique design access chamber enabling up to 4 inlet connections from shallow drains Single outlet at centre of base of bowl enables connection to underlying drain run up to 10 metres deep without need for manholes. Bowl shape and inlet angles create self-cleaning swirl action.</p> <table border="1" data-bbox="534 1198 1053 1288"> <thead> <tr> <th>size(mm)</th> <th>A</th> <th>B</th> <th>C</th> <th>D</th> <th>L</th> <th>Z</th> </tr> </thead> <tbody> <tr> <td>110</td> <td>496</td> <td>110</td> <td>154</td> <td>432</td> <td>308</td> <td>230</td> </tr> </tbody> </table>	size(mm)	A	B	C	D	L	Z	110	496	110	154	432	308	230	<table border="1" data-bbox="1093 1198 1492 1288"> <thead> <tr> <th>Code</th> <th>Col</th> <th>Pk/bx</th> </tr> </thead> <tbody> <tr> <td>4DMB</td> <td>T</td> <td>1/2</td> </tr> </tbody> </table>	Code	Col	Pk/bx	4DMB	T	1/2
size(mm)	A	B	C	D	L	Z																
110	496	110	154	432	308	230																
Code	Col	Pk/bx																				
4DMB	T	1/2																				
<p>INLET CONNECTOR FOR MARSCAR ACCESS BOWL</p> 	<p><i>Material:</i> Polypropylene Pre-cut inlet hole for connection of 110mm pipe 2-part component: connector with seal and locking cap</p> <table border="1" data-bbox="534 1556 1053 1646"> <thead> <tr> <th>size(mm)</th> <th>A</th> <th>Z1</th> <th>Z2</th> </tr> </thead> <tbody> <tr> <td>110</td> <td>180</td> <td>90</td> <td>162</td> </tr> </tbody> </table>	size(mm)	A	Z1	Z2	110	180	90	162	<table border="1" data-bbox="1093 1556 1492 1646"> <thead> <tr> <th>Code</th> <th>Col</th> <th>Pk/bx</th> </tr> </thead> <tbody> <tr> <td>4DM1</td> <td>T</td> <td>5/20</td> </tr> </tbody> </table>	Code	Col	Pk/bx	4DM1	T	5/20						
size(mm)	A	Z1	Z2																			
110	180	90	162																			
Code	Col	Pk/bx																				
4DM1	T	5/20																				

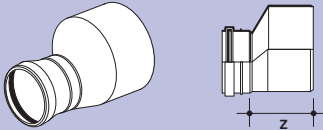
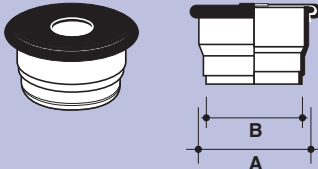
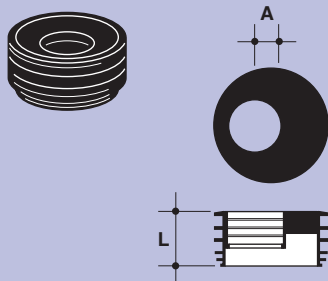
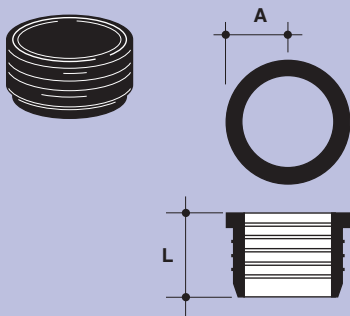
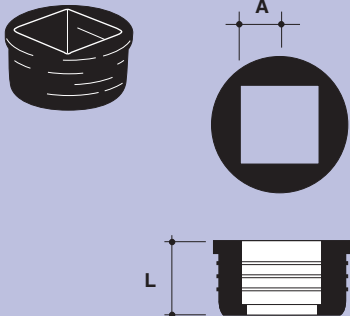
<p>LEVEL INVERT TAPER</p> 	<p><i>Material: PVC-u</i> Larger end spigot and smaller end socket</p> <table border="1"> <thead> <tr> <th>size(mm)</th> <th>Z</th> </tr> </thead> <tbody> <tr> <td>110/82</td> <td>104</td> </tr> <tr> <td>160/110</td> <td>143</td> </tr> </tbody> </table>	size(mm)	Z	110/82	104	160/110	143	<table border="1"> <thead> <tr> <th>Code</th> <th>Col</th> <th>Pk/bx</th> </tr> </thead> <tbody> <tr> <td>43DT</td> <td>T</td> <td>2/24</td> </tr> <tr> <td>64DT</td> <td>T</td> <td>4/24</td> </tr> </tbody> </table>	Code	Col	Pk/bx	43DT	T	2/24	64DT	T	4/24									
size(mm)	Z																									
110/82	104																									
160/110	143																									
Code	Col	Pk/bx																								
43DT	T	2/24																								
64DT	T	4/24																								
<p>UNIVERSAL RAINWATER ADAPTOR</p> 	<p>For connecting round and square PVC-u rainwater downpipe (up to 68mm) to underground drainpipe</p> <table border="1"> <thead> <tr> <th>size(mm)</th> <th>A</th> <th>B</th> </tr> </thead> <tbody> <tr> <td>110</td> <td>110</td> <td>102</td> </tr> </tbody> </table>	size(mm)	A	B	110	110	102	<table border="1"> <thead> <tr> <th>Code</th> <th>Col</th> <th>Pk/bx</th> </tr> </thead> <tbody> <tr> <td>4D76</td> <td>T</td> <td>10/50</td> </tr> </tbody> </table>	Code	Col	Pk/bx	4D76	T	10/50												
size(mm)	A	B																								
110	110	102																								
Code	Col	Pk/bx																								
4D76	T	10/50																								
<p>UNIVERSAL WASTE ADAPTOR</p> 	<p><i>Material: EPDM</i> For connecting 32mm, 40mm or 50mm waste pipe to 110mm underground drain pipe</p> <table border="1"> <thead> <tr> <th>size(mm)</th> <th>A</th> <th>L</th> </tr> </thead> <tbody> <tr> <td>110</td> <td>8</td> <td>40</td> </tr> </tbody> </table>	size(mm)	A	L	110	8	40	<table border="1"> <thead> <tr> <th>Code</th> <th>Col</th> <th>Pk/bx</th> </tr> </thead> <tbody> <tr> <td>4DW200</td> <td>B</td> <td>5/60</td> </tr> </tbody> </table>	Code	Col	Pk/bx	4DW200	B	5/60												
size(mm)	A	L																								
110	8	40																								
Code	Col	Pk/bx																								
4DW200	B	5/60																								
<p>ADAPTOR TO ABOVE GROUND DRAIN</p> 	<p><i>Material: Flex PVC</i> For connecting 68mm downpipes and 82mm underground drain</p> <p>For round downpipe</p> <table border="1"> <thead> <tr> <th>size(mm)</th> <th>A</th> <th>L</th> </tr> </thead> <tbody> <tr> <td>82/68</td> <td>41</td> <td>54</td> </tr> <tr> <td>110/68</td> <td>10</td> <td>54</td> </tr> <tr> <td>110/82</td> <td>56</td> <td>54</td> </tr> </tbody> </table>	size(mm)	A	L	82/68	41	54	110/68	10	54	110/82	56	54	<table border="1"> <thead> <tr> <th>Code</th> <th>Col</th> <th>Pk/bx</th> </tr> </thead> <tbody> <tr> <td>3DW25</td> <td>B</td> <td>5/60</td> </tr> <tr> <td>4DW25</td> <td>B</td> <td>5/50</td> </tr> <tr> <td>4DW3</td> <td>B</td> <td>5/50</td> </tr> </tbody> </table>	Code	Col	Pk/bx	3DW25	B	5/60	4DW25	B	5/50	4DW3	B	5/50
size(mm)	A	L																								
82/68	41	54																								
110/68	10	54																								
110/82	56	54																								
Code	Col	Pk/bx																								
3DW25	B	5/60																								
4DW25	B	5/50																								
4DW3	B	5/50																								
<p>ADAPTOR TO ABOVE GROUND DRAIN</p> 	<p><i>Material: Flex PVC</i> For connecting 62mm or 75mm square downpipes to underground drainage system</p> <p>For square downpipe</p> <table border="1"> <thead> <tr> <th>size(mm)</th> <th>A</th> <th>L</th> </tr> </thead> <tbody> <tr> <td>110/62</td> <td>56</td> <td>54</td> </tr> </tbody> </table>	size(mm)	A	L	110/62	56	54	<table border="1"> <thead> <tr> <th>Code</th> <th>Col</th> <th>Pk/bx</th> </tr> </thead> <tbody> <tr> <td>4DW23</td> <td>B</td> <td>5/50</td> </tr> </tbody> </table>	Code	Col	Pk/bx	4DW23	B	5/50												
size(mm)	A	L																								
110/62	56	54																								
Code	Col	Pk/bx																								
4DW23	B	5/50																								

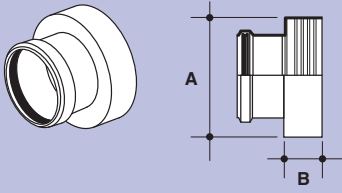
<p>PVC-U UNDERGROUND DRAIN PIPE TO CLAY</p> 	<p><i>Material:</i> PVC-u Socket for PVC-u drain pipe and ribbed socket for other material</p> <table border="1"> <thead> <tr> <th>size(mm)</th> <th>A</th> <th>B</th> </tr> </thead> <tbody> <tr> <td>110</td> <td>154</td> <td>50</td> </tr> <tr> <td>160</td> <td>213</td> <td>57</td> </tr> </tbody> </table>	size(mm)	A	B	110	154	50	160	213	57	<table border="1"> <thead> <tr> <th>Code</th> <th>Col</th> <th>Pk/bx</th> </tr> </thead> <tbody> <tr> <td>4D73</td> <td>T</td> <td>1/36</td> </tr> <tr> <td>6D73</td> <td>T</td> <td>1/15</td> </tr> </tbody> </table>	Code	Col	Pk/bx	4D73	T	1/36	6D73	T	1/15						
size(mm)	A	B																								
110	154	50																								
160	213	57																								
Code	Col	Pk/bx																								
4D73	T	1/36																								
6D73	T	1/15																								
<p>CLEANING FLUID</p>	<p><i>Material:</i> Acetone. For cleaning PVC-u pipe and fittings before applying Liquid Weld. Screw top cans.</p> <table border="1"> <thead> <tr> <th>size(ml)</th> </tr> </thead> <tbody> <tr> <td>125</td> </tr> <tr> <td>250</td> </tr> </tbody> </table>	size(ml)	125	250	<table border="1"> <thead> <tr> <th>Code</th> <th>Col</th> <th>Pk/bx</th> </tr> </thead> <tbody> <tr> <td>9101.125</td> <td></td> <td>12/24</td> </tr> <tr> <td>9101.250</td> <td></td> <td>12/24</td> </tr> </tbody> </table>	Code	Col	Pk/bx	9101.125		12/24	9101.250		12/24												
size(ml)																										
125																										
250																										
Code	Col	Pk/bx																								
9101.125		12/24																								
9101.250		12/24																								
<p>LUBRICANT</p>	<p><i>Material:</i> Silicone grease or Soluble lubricant. For lubricating seal rings on expansion fittings.</p> <table border="1"> <thead> <tr> <th>size(ml)</th> <th></th> <th></th> </tr> </thead> <tbody> <tr> <td>50</td> <td>Tube</td> <td>(Silicone)</td> </tr> <tr> <td>250</td> <td>Tub</td> <td>(Silicone)</td> </tr> <tr> <td>500</td> <td>Tub</td> <td>(Soluble)</td> </tr> </tbody> </table>	size(ml)			50	Tube	(Silicone)	250	Tub	(Silicone)	500	Tub	(Soluble)	<table border="1"> <thead> <tr> <th>Code</th> <th>Col</th> <th>Pk/bx</th> </tr> </thead> <tbody> <tr> <td>9136.50</td> <td></td> <td>1/150</td> </tr> <tr> <td>9136.250</td> <td></td> <td>1/40</td> </tr> <tr> <td>9136.500</td> <td></td> <td>1/20</td> </tr> </tbody> </table>	Code	Col	Pk/bx	9136.50		1/150	9136.250		1/40	9136.500		1/20
size(ml)																										
50	Tube	(Silicone)																								
250	Tub	(Silicone)																								
500	Tub	(Soluble)																								
Code	Col	Pk/bx																								
9136.50		1/150																								
9136.250		1/40																								
9136.500		1/20																								
<p>LIQUID WELD</p>	<p>For solvent jointing of PVC-u pipes and fittings cap incorporates integral brush.</p> <table border="1"> <thead> <tr> <th>size(ml)</th> </tr> </thead> <tbody> <tr> <td>♥ 125</td> </tr> <tr> <td>♥ 250</td> </tr> <tr> <td>♥ 500</td> </tr> </tbody> </table>	size(ml)	♥ 125	♥ 250	♥ 500	<table border="1"> <thead> <tr> <th>Code</th> <th>Col</th> <th>Pk/bx</th> </tr> </thead> <tbody> <tr> <td>9100.125</td> <td></td> <td>12/24</td> </tr> <tr> <td>9100.250</td> <td></td> <td>12/24</td> </tr> <tr> <td>9100.500</td> <td></td> <td>1/12</td> </tr> </tbody> </table>	Code	Col	Pk/bx	9100.125		12/24	9100.250		12/24	9100.500		1/12								
size(ml)																										
♥ 125																										
♥ 250																										
♥ 500																										
Code	Col	Pk/bx																								
9100.125		12/24																								
9100.250		12/24																								
9100.500		1/12																								

Handling

- Take all reasonable care when handling PVC-u, particularly in very cold conditions when the impact strength of the material is reduced
- Do not throw or drop pipes, or drag them along hard surfaces
- In case of mechanical handling, use protective slings and padded supports. Metal chains and hooks should not make direct contact with the pipe

On-site storage

- Stack pipe lengths:
 - either on a flat base
 - or on level ground
 - or on 75mm x 75mm timber at 1.0m maximum centres

- Provide side support with 75mm wide battens at 1m centres (Fig. 1)
- Maximum stack: seven layers high
- Ideally, stacks should contain one diameter pipe size only. Where this is not possible, stack largest diameter pipes at base of stack. Small pipes may be nested inside larger pipes
- If stored in the open for long periods, or exposed to strong sunlight, cover the stack with opaque sheeting
- Store fittings under cover. Do not remove from cartons or packaging until required

- Store solvent cement and cleaning fluid in a cool place in accordance with the relevant regulations detailed in the Health & Safety at Work Act 1974

Site safety

- The relevant regulations detailed in the Health & Safety at Work Act 1974, and Construction (Design & Management) Regulations 1995, must be adhered to on site
- COSHH data sheets are available on request

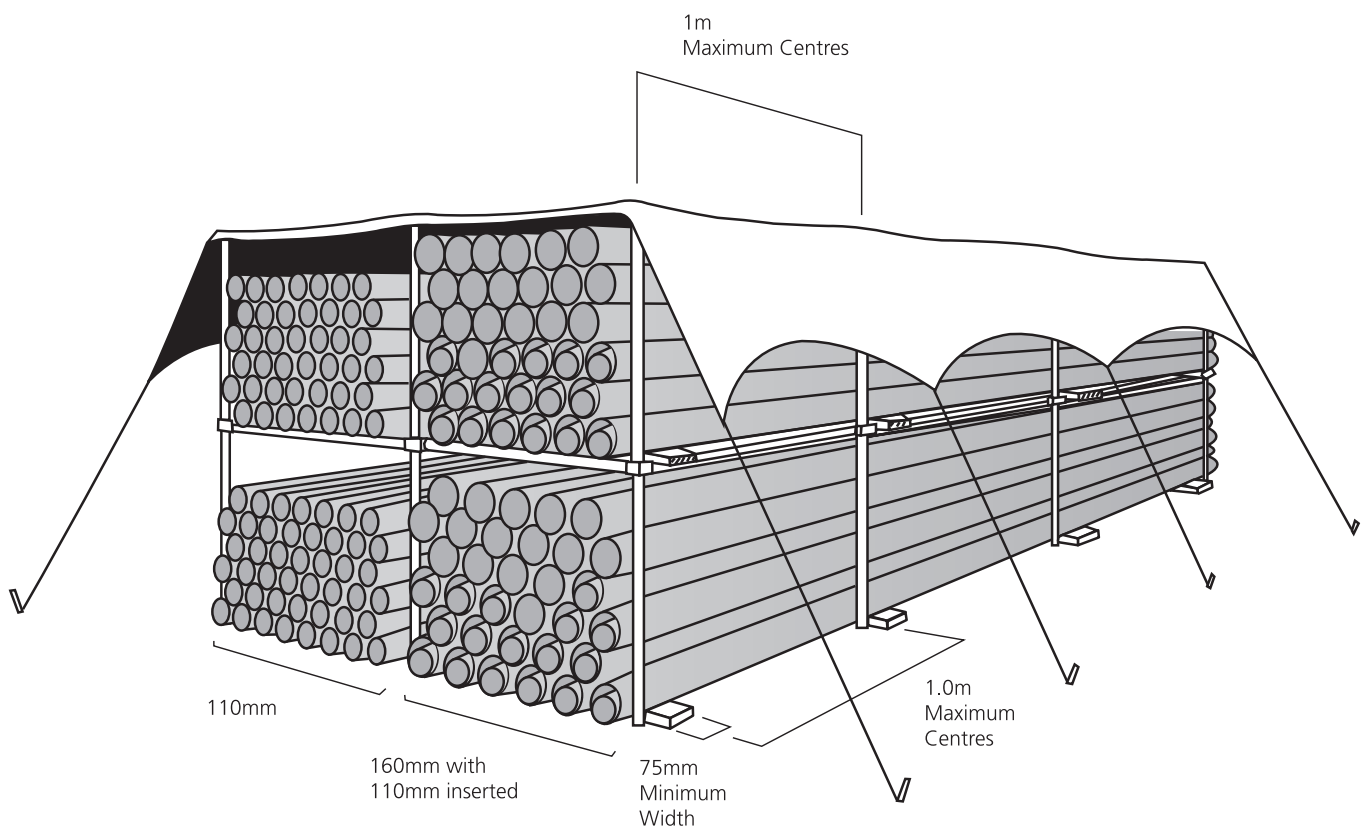

Fig. 1 Pipe stacking

Seal ring jointing

IMPORTANT: A 9mm expansion gap must be created at all seal ring joints to allow pipes to expand or contract without stressing during wide temperature variations.

Step 1

Pipe lengths are supplied ready-chamfered. For site-cut pipes and offcuts, ensure cut is square – then file ends to provide 45° external chamfer. (Do not chamfer to a knife edge.) Lubricate rubber seal with **9136 Lubricant** (Fig. 2a).

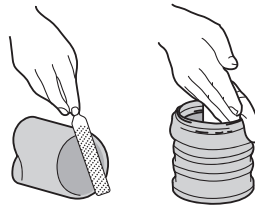

Fig. 2a Filing chamfer

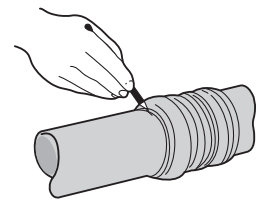

Fig. 2b Pushing in pipe/markering pipe

Step 2

Push pipe fully into socket. Mark pipe against socket edge as shown (Fig. 2b).

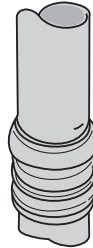

Fig. 2c Pipe withdrawn by 9mm

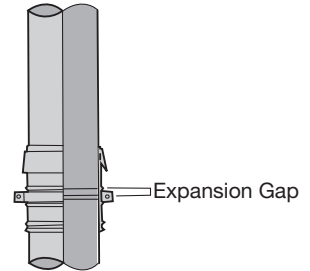

Fig. 2d Expansion gap

Step 3

Withdraw pipe until mark is 9mm from socket edge to provide required expansion gap (Figs 2c and 2d).

Solvent cement jointing

Step 1

Cut pipe square, deburr and clean mating surfaces with **9101 Cleaning Fluid** (Fig. 3a).

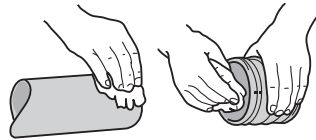

Fig. 3a Preparing pipe

Step 2

Coat mating surfaces with **9100 Liquid Weld**, using brush supplied (125ml, 250ml and 500ml cans) (Fig. 3b).

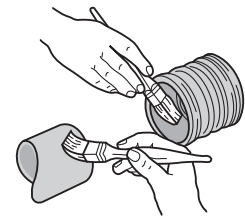

Fig. 3b Applying cement

Step 3

Assemble joint immediately, removing any excess cement with a clean rag.

Initial set: 3–4 minutes.

Final set: 12 hours.

CAUTION: Closely follow directions for use of Liquid Weld as printed on the container label.

Pipe bedding and backfill

All bedding and backfilling of Terrain Underground pipes should be in accordance with BS 5955: Part 6 Installation of PVC-u pipework for gravity drains and sewers, or the BBA Certificate.

Terrain 110mm and 160mm PVC-u underground drainage systems have been awarded British Board of Agrément Certificate No. 94/3049. This allows:

- 50mm depth of granular bedding (see Fig. 5)
- Where the as-dug soil is suitable, pipes may be laid directly on a trimmed trench bottom (Fig. 4)

Suitable material is defined as granular material in accordance with the recommendations of BS 5955: Part 6: 1980 having a nominal particle size not exceeding 10mm or 14mm for 110mm and 160mm diameter pipes respectively, or that which passes the tests described in appendix A of the above standard.

Where the as-dug material is unsuitable

A bed of suitable imported granular material must be laid on the trench bottom prior to installation of pipes and be used for sidefill up to the level of the crown of the pipe.

If the trench may be hand trimmed by shovel and is not puddled when walked on, a bed of 50mm is sufficient (Fig. 5).

When pipes are to be laid in hard ground requiring mechanical means of trimming (e.g. rock, compacted sand or gravel), or in very soft or wet ground, a bed of min. 100mm is required (Fig. 6).

Drains under Buildings

Where drains are required to be laid under buildings, deep hardcore from within the foundation boundaries should be compacted prior to excavating the trench for the pipe. Suitable material should then be employed for the bedding and backfilling.

When trenches are dug from original ground, pipes may be laid and surrounded with appropriate material before the top layer of hardcore is placed.

Where pipes pass through a wall or foundations of a building, they should be protected by a lintel or sleeve.

Requirements for imported material for backfill

NOMINAL PIPE SIZE	MATERIAL COMPLYING WITH BS 882: 1992
110mm	10mm nominal single-sized aggregate
160mm	14mm nominal single-sized aggregate

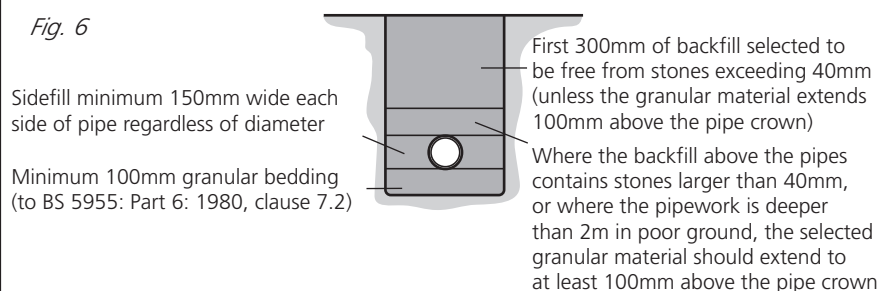
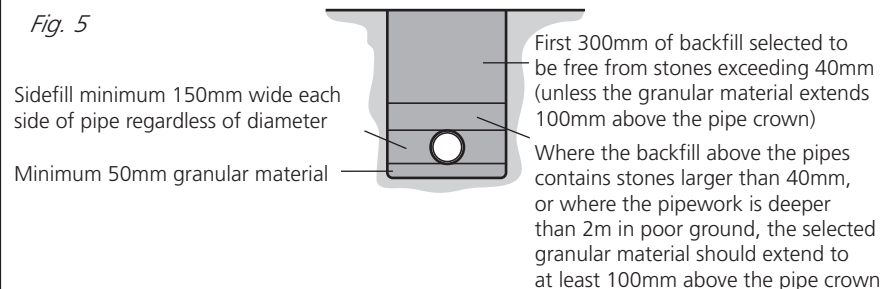
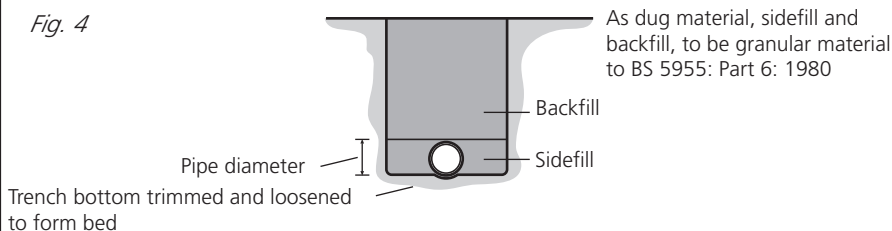

Shallow drains

Where there is risk of damage, pipes laid at less than 600mm depth (not under a road) should be protected by use of a paving slab or similar. A minimum 75mm cushioning layer of granular material must be laid between any slab and the crown of the pipe.

Pipes laid under roads

The minimum cover under roads should be 1.2m from the top of the pipe. Where this is less than 1.2m additional protection is required ie reinforced bridging slabs.

Rodding points

Rodding points may be used on drains with invert depths up to 2m. They may be located at the head of a drain or at intermediate positions as an alternative to an inspection chamber or manhole. However,

- Because rodding is possible in the direction of flow only, sufficient rodding points must be incorporated to provide access to all parts of the drain
- As it is not possible to remove debris from a rodding point, an inspection chamber or manhole must be provided at a point downstream

During installation, care must be taken to ensure no load is transferred onto the branch upstand of the pipe.

Shallow inspection chamber

Provides an alternative to traditional manholes for invert depths up to 600mm. Intermediate depths can be accommodated by cutting chamber riser with a fine-tooth saw.

The base unit is supplied with two contoured plugs sealing the two side connections. For left or right hand single connections, the appropriate plug is removed.

The **4DI600 Shallow Inspection Chamber** can be used with **4DIFC1 Sealed Cover and Frame** (PVC-u) (Fig. 7).

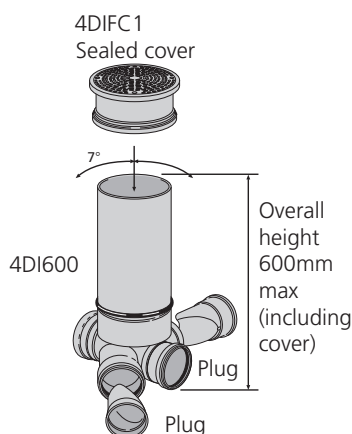

Fig. 7

If situated in an area where it may be damaged, the frame should be surrounded with concrete to prevent movement and provide extra security.

Inspection chamber

The Terrain **4DI240B Inspection Chamber** provides an alternative to traditional manholes for invert depths up to 1.2 metres. It comprises a base unit and three raising pieces (**4DI235R**) to allow a range of heights to be easily achieved (Fig. 8).

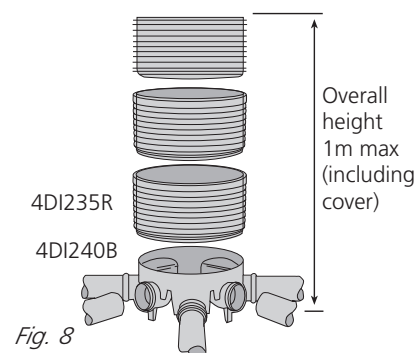

Fig. 8

Overall heights

(including cast iron frame and cover)

Base unit	285mm
Base unit plus 1 raising piece	520mm
Base unit plus 2 raising pieces	755mm
Base unit plus 3 raising pieces	990mm
Base unit plus 4 raising pieces	1225mm

Intermediate heights can be achieved by cutting the top raising piece as necessary.

Chambers should be installed on a 100mm bed of suitable granular material or as dug material. The bedding material must be evenly compacted under the base so that the chamber is fully supported.

Different covers are available to meet varying application requirements:

C.I. cover/PP frame to BS EN 124 Class A (4DIFC3): for use in areas inaccessible to motor vehicles and industrial trolleys (Fig. 9)

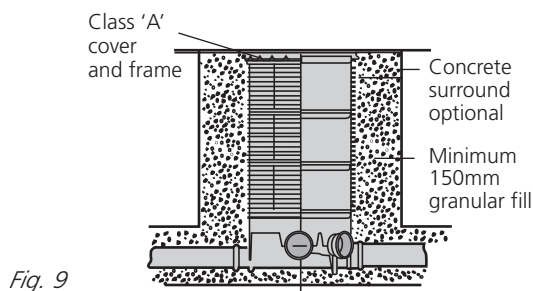

Fig. 9

Polypropylene cover and frame (4DIFC4): for use where cars and light vehicles have access but NOT heavy vehicles (Fig. 10) rated to 35kN

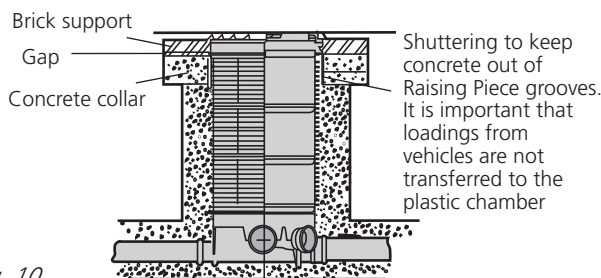

Fig. 10

Class B cover C.I. (by others): for use in areas subject to occasional slow moving commercial vehicle trafficking (Fig. 10)

Unequal inspection chamber

Suitable for invert depths of up to 1.2mtrs, the **6DI750 Unequal Inspection Chamber** incorporates a through drain of 160mm and side connections of 110mm (*Fig. 11*).

The specific required height can be achieved by cutting the chamber body or extension piece (**6DI250**) with a fine-tooth saw.

The unit is supplied with all inlets and outlets blanked off. These are easily opened for use by cutting off the ends with a fine tooth saw.

The appropriate cover should be selected, as for the Terrain Inspection Chamber. For installation details see page 15. *Figs 9 and 10* also apply.

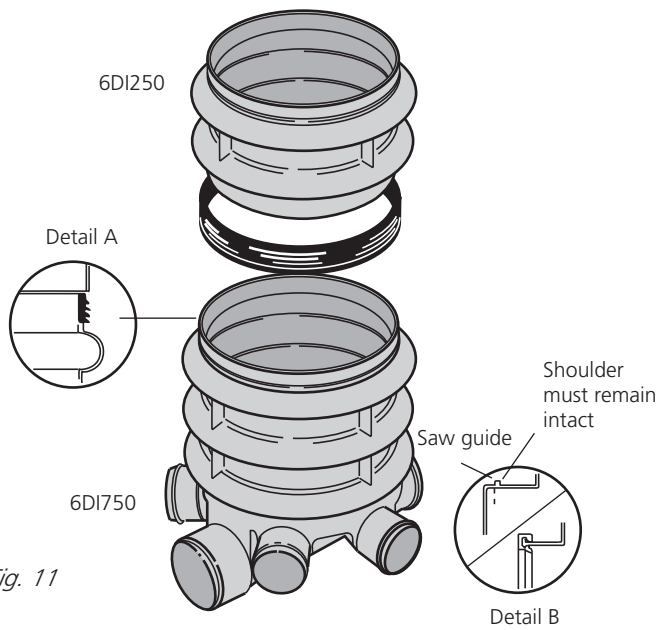

Fig. 11

Brick or concrete ring manholes

One or more inspection chamber bases **4DI240B** or **6DI750** with upstand removed may be used at the base of manholes as an alternative to benching in half channel or slip couplings.

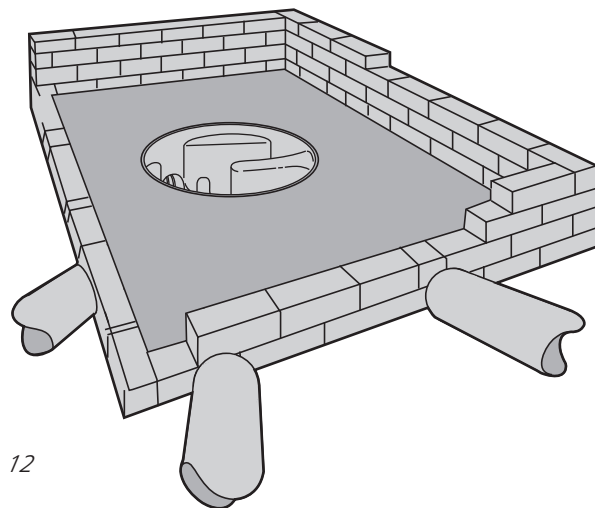

Fig. 12

Bottle Gully – Square cover (Fig. 13)

The frame and cover may be rotated to meet site requirements, and the square grid cut away to suit rainwater or waste pipe entry.

The back inlet socket is suitable for solvent weld connection of 110mm diameter pipe. A push-in blank plug is supplied for use when connection is not required.

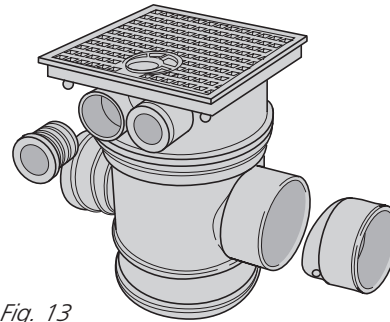

Fig. 13

To connect waste pipes to back inlet bosses

Remove rubber plug from side bosses and solvent-weld appropriate fitting (Fig. 14):

For straight connectors

32mm	117.125
40mm	117.15
50mm	117.2

For 90° bend connectors

32mm	117.15.90 and 224.15.125
40mm	117.15.90
50mm	117.2.90

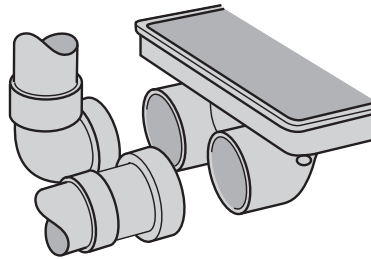

Fig. 14

NOTE: The height of the cover and frame (with the back inlets) may be raised by cutting off the spigot and extending with 200mm pipe.

Bottle Gully – Round cover (Fig. 15)

To connect 110mm pipe to back inlet socket

Remove polypropylene plug and solvent-weld pipe or spigot of fitting.

The gully may be extended by using the 4DG96 Raising Piece (Fig. 16).

The grating and frame should be removed from the gully and the raising piece inserted. The grating should then be fixed to the top of the raising piece. The original gully frame unit should be discarded.

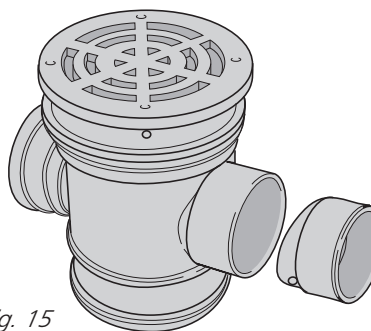

Fig. 15

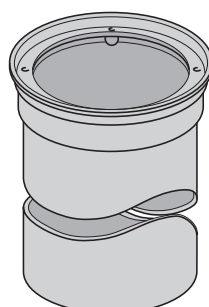
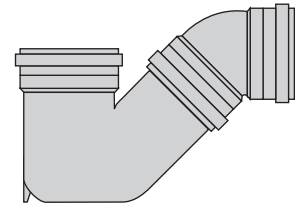

Fig. 16

Gully Traps/Bend Arrangements

P Trap

■ Use 4DG90 Gully Trap and 4D25D Bend 45° (Fig. 17)



'P' Trap

Fig. 17

■ Alternatively use 4DG91 P-Trap

Q Trap

■ Use 4DG90 Gully Trap and 4D23D Bend 87¹/₂° (Fig. 18)

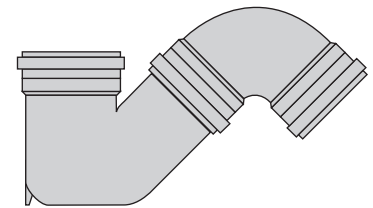

'Q' Trap

Fig. 18

S Trap

■ Use 4DG90 Gully Trap with 4D23D Bend 87¹/₂° and 4D25 Bend 45° (Fig. 19)

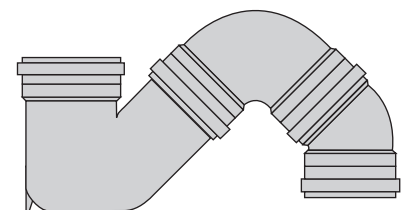

'S' Trap

Fig. 19

Circular Gully and Traps (Fig. 20)

This 4DG80 gully is designed to accept both the 4DG82 Sealed Cover and the 4DG83 Circular Grating.

Where required, the unit may be extended by fitting the 4DG81 Extension Piece into the top of the gully.

The gully fitting incorporates:

- 2 x side spigot inlets (110mm dia spigots)
- 1 x 110mm ring seal socket inlet
- 1 x 68mm spigot inlet, to accept rainwater pipe

Each inlet is fitted with a removable polypropylene plug.

The 110mm spigot outlet may be removed – by cutting with a fine-tooth hand saw – to leave a socket to accept 110mm pipe with solvent-weld joint.

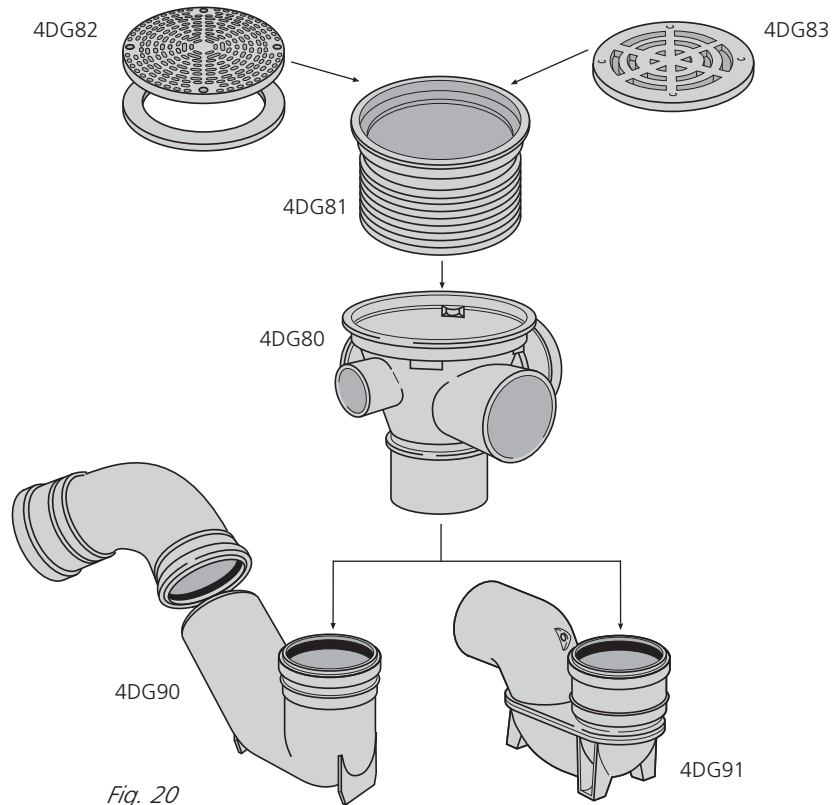

Fig. 20

Hoppers and Traps (Fig. 21)

Hoppers are supplied with open grids which snap into place. Sealed covers are available and should be secured using the self-tapping screws provided.

The 110mm spigot outlets may be removed – by cutting with a fine-tooth hand saw – to leave a socket to accept 110mm pipe with solvent-weld joint

To connect waste pipe to side bosses

- Drill out blanking plug using a 51mm diameter hole saw
- Solvent-weld appropriate fitting:

For straight connectors

32mm	117.125
40mm	117.15
50mm	117.2

For 90° bend connectors

32mm	117.15.90 and 224.15.125
40mm	117.15.90
50mm	117.2.90

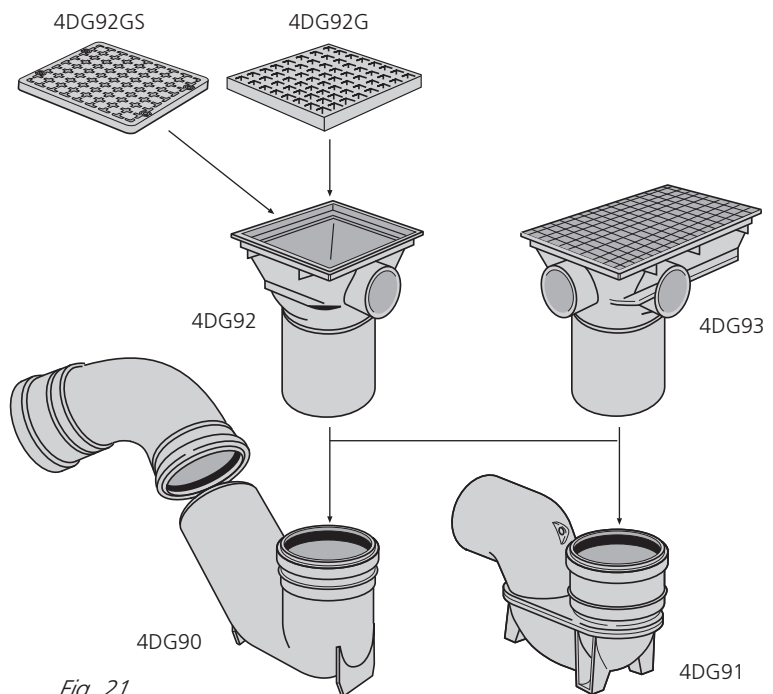

Fig. 21

Rocker Pipe assembly (Fig. 22)

The rocker pipe assembly is designed for applications where greater levels of settlement may be expected.

By using an assembly of 4D79 Rocker Pipe Connector and 4D20D Coupler (double socket) and a length of pipe (600mm maximum), up to 53mm of settlement may be accommodated

The Rocker pipe assembly may also be used for situations where pipe leaving a building deflects down a gradient. A maximum deflection of 5° can be achieved (Fig. 23)

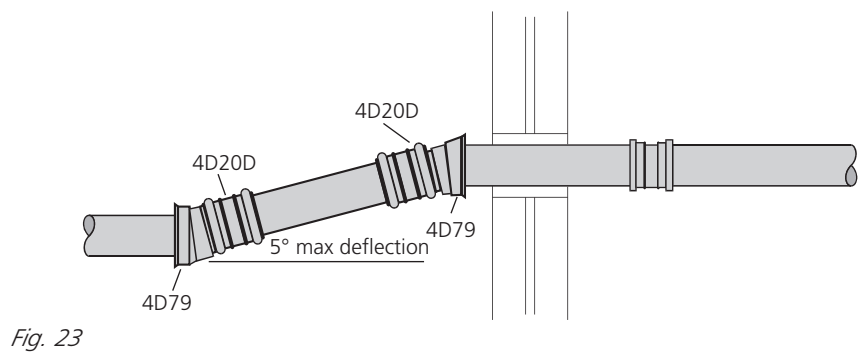
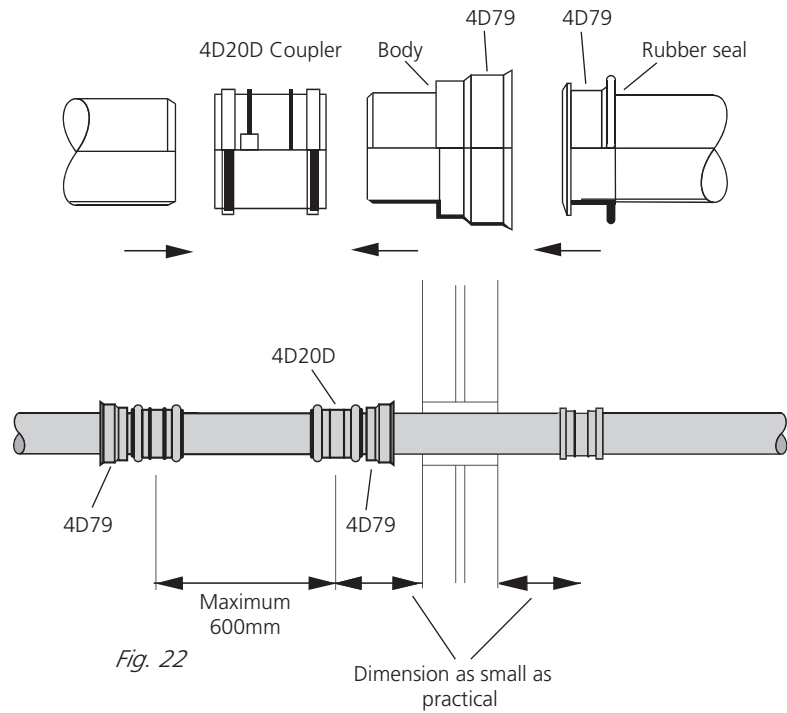

Marscar system

The 4DMB Marscar Bowl has 4 inlet options. One is open, the other 3 are blanked off with removable caps (Fig. 24). An additional 2 inlets may be cut into the bowl if required.

Up to 3 raising pieces (4DI235R) are available to achieve a maximum invert depth of bowl of 1m. The final raising piece may be cut as necessary to reach precise height required.

All items – outlet, pipework, junction or bend – are assembled using standard ‘push-fit’ jointing procedures. No special sealing compound is required. See page 15, Figs 9 and 10 for cover and frame installation details.

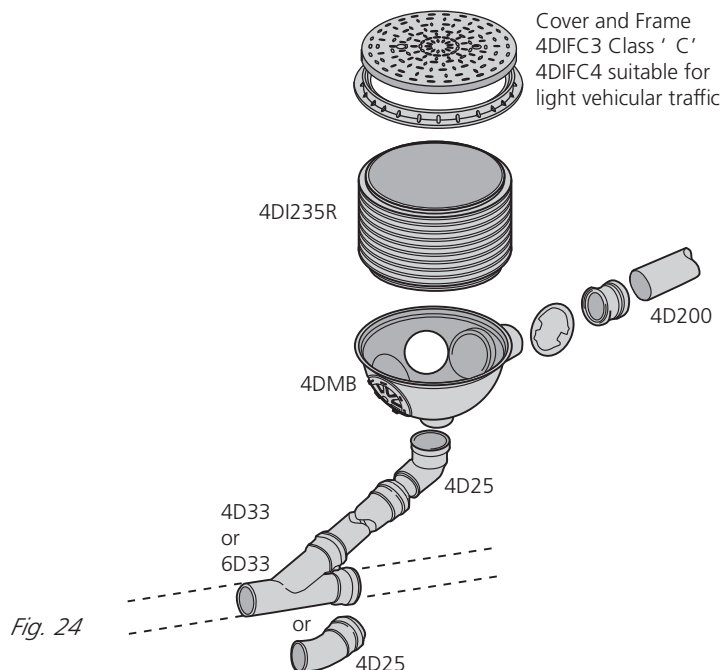

Design

The bowl may be rotated in any direction to suit lateral connections, even against the flow.

The four pre-cut inlets are each adjustable by varying degrees to accommodate pipe runs.

*For areas outside adjustment and to overcome changes in vertical angle or entry when rotating the pipe:

EITHER

- 4DV40 Variable Bend may be used

OR,

- 4D25D Bend 45° will achieve maximum adjustment to align inlet with pipe runs

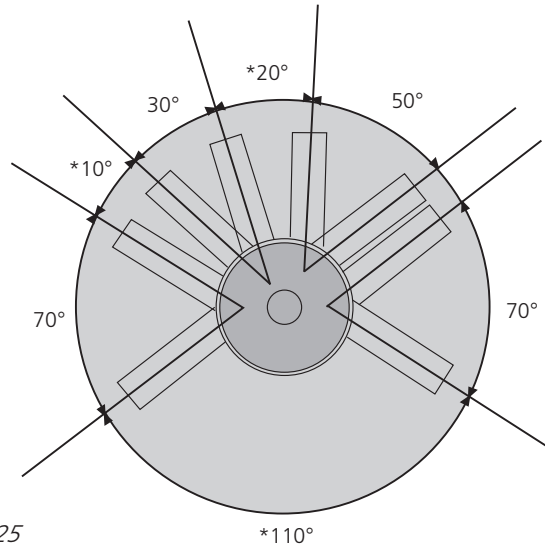

Fig. 25

Optimum cleansing of bowl

To achieve optimum cleansing of bowl, the inlet should be orientated to create circular flow (Fig. 26a).

The desired angle of entry may be achieved by rotating the bowl and using an additional bend (up to 45°) to align with branch drain (Fig. 26b).

Inlet(s) positions which will cause flow directly across the bowl should be avoided (Fig. 26c).

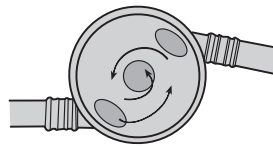

Fig. 26a

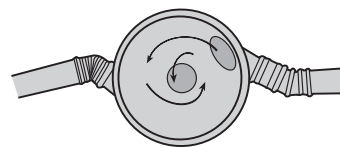

Fig. 26b

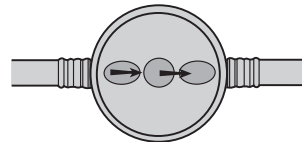

Fig. 26c

Drop-out pipe lengths

Depth*	B: Drop-out pipe effective length		
	110mm bend	110mm junction	160mm junction
mm	mm	mm	mm
220	0	n/a	n/a
500	460	355	290
750	815	710	640
1000	1170	1065	995
1250	1525	1415	1350
1500	1875	1770	1700
1750	2230	2125	2055
2000	2585	2475	2410

* Depth from invert of bowl to invert of pipe

Invert depths and drop-out pipe lengths

The following tables allow assessment of invert depths (Fig. 27), effective lengths of drop-out pipe, and linear displacement for Marscar bowl installation:

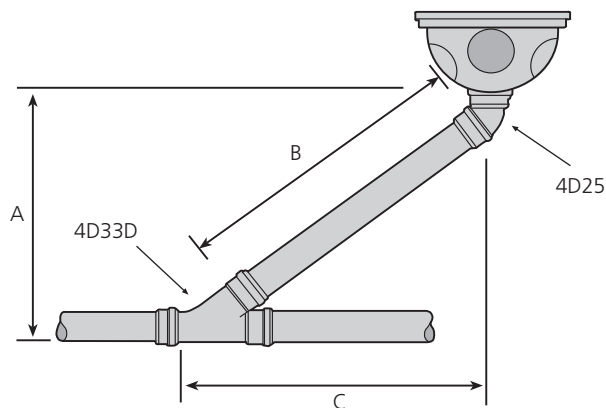

Fig. 27

NOTE: Linear displacement 'C' is approx the same as the depth 'A'

System connections to above ground drainage

Connecting to soil system
(soil pipe to EN 1329)

- **110mm Underground Pipe to 110mm Soil Pipe**
110mm Underground Pipe may be connected directly to 110mm Soil Pipe (Fig. 28)
- A 45° external chamfer should be filed onto the end of square cut soil pipe. The soil pipe is then push-fit into the underground drain ring seal socket, using **9136 Lubricant**

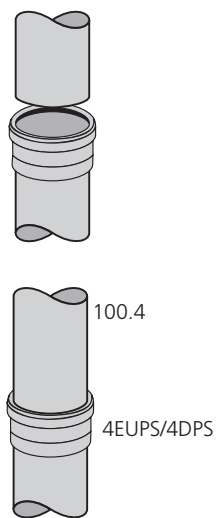

Fig. 28

- **110mm Underground Pipe to 82mm Soil Pipe (Fig. 29)**
Connection should be made using the **4DW3 Socket Reducer**.
The socket reducer is inserted into the plain end of the underground pipe. The 82mm soil pipe is then pushed into top of reducer

Connecting to waste system (waste pipe to BS 5255/EN 1566)
Connection is made using the **124 Socket Reducer**.

The socket reducer is pushed into the ring seal of socket on underground drain pipe. The waste pipe is solvent-welded into reducer. Additional reducers may be used as required.

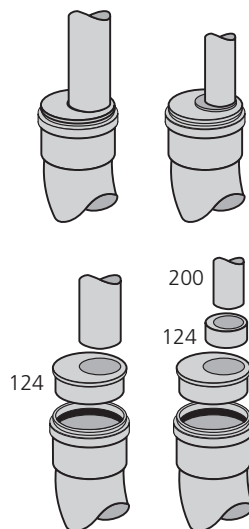

Fig. 29

Connecting to rainwater OR waste system (using rubber adaptor) (Fig. 30)

The **4DW Adaptor** enables simple push-fit connection of 110mm underground pipe to waste or rainwater systems. It is available for the following pipe sizes:

Rainwater:

- 68mm round – 4DW25
- 62mm square – 4DW23
- 82mm round – 4DW3

Waste:

- 32mm – 4DW200
- 40mm
- 50mm

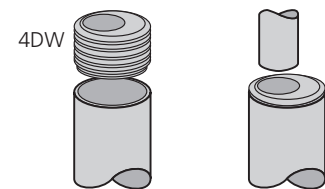

Fig. 30

Connecting to BS 5255/5254/EN 1566 waste pipe (Fig. 31)

(also to copper waste pipe)

The centre of **4D68/6D68 Socket Plug** should be drilled out, ready for solvent-weld connection of the appropriate size **4DW Boss Adaptor**.

Seal rings on 4DW and underground drain socket should be lubricated using **9136 Lubricant**.

The socket plug is then inserted into underground drain socket and **200 Waste Pipe** (or copper waste pipe) into 4DW adaptor.

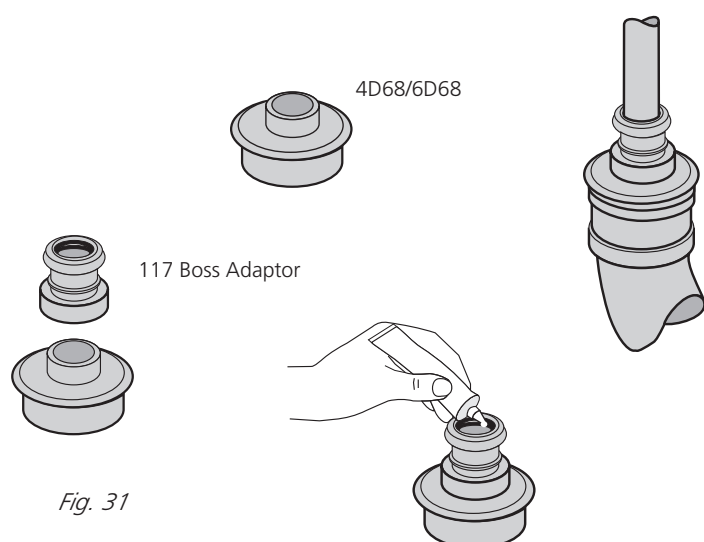

Fig. 31

Connections to other materials

Terrain PVC-u underground pipe to:

Ductile iron

Timesaver coupling TD02, clamped directly onto butted pipes (Fig. 32).

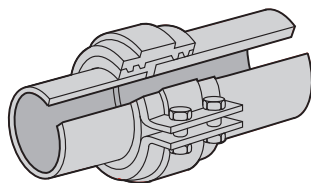
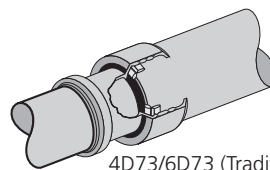

Fig. 32

Clay spigot

For traditional clay: **4D73/6D73** (Fig. 33).



4D73/6D73 (Traditional Clay)

Fig. 33

WC Connections (Fig. 34)

Provide solvent cement joint between **128.4.90 WC Connector (single socket)** and WC outlet.

A length of **100.4 Soil Pipe** is added between WC Connector and **Socketed Drain Pipe**.

NOTE: The level of the drain socket is not critical as the 100.4 Soil Pipe can be cut to length.

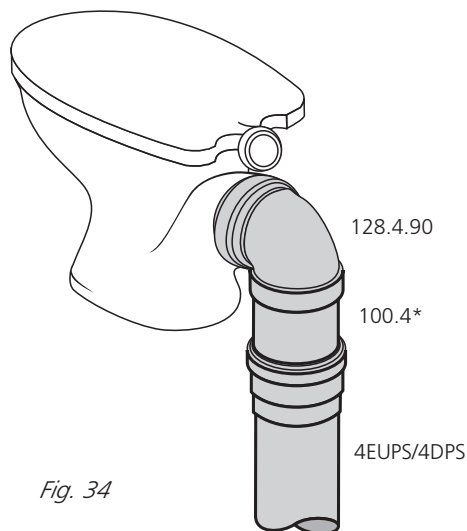

Fig. 34

Suspended Pipework

PURPOSE: To ensure that, where drainage pipework has to pass through an undercroft or basement area:

- it is properly supported throughout any suspended run
- its integrity is maintained and protected from the consequences of thermal expansion or contraction

Support and Expansion Distances

Pipe size	Max. support distances		Max. distance between expansion joints
	Vertical	Horizontal	
82	2m	0.9m	4m
110	2m	1m	4m
160	2m	1m	4m

Fig. 35

Recommended support centres

- Fit **191 Intermediate Support Brackets*** for suspended pipework at recommended regular intervals (see Fig. 35). These may be attached to 8mm drop rods (supplied by others) fixed into ceiling or soffit above pipework.
- Install expansion joints (see *Seal Ring Joining*, page 13) at recommended centres along the suspended pipe run. Where the suspended run is lengthy, the expansion joints must be installed with a **190 Thermal Movement Limiter** (page 23)

- The following maximum distances apply:
 - Pipe support brackets: 1m centres (*maximum*)
 - Expansion joints: 4m centres (*maximum*)

NOTE: If two fixed points are more than 1 metre apart, an expansion joint is also required

*82mm pipes must be supported at maximum 0.9m centres

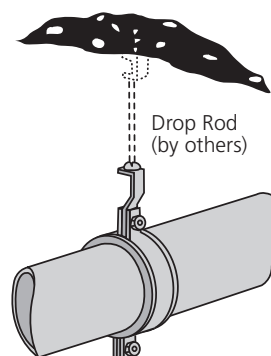

Fig. 35a Horizontal support

Installation of 190 Thermal Movement Limiter (TML)

Step 1

Clean the surface of the pipe in front of the expansion socket, and the inner surface of the PVC-u split collar, with **9101 Cleaning Fluid** using a dry, clean, natural fibre cloth (NOT synthetic).

Step 2

After setting the 18mm expansion gap (see page 13) Solvent-weld split collar to pipe ensuring that when assembled the bolts pass through the centre of the restraining bar slots (see Fig. 37).

Step 3

Assemble and locate brackets: one around the split collar, and the other around the expansion socket.

Step 4

Couple the brackets together with the two slotted restraining bars (which restrict horizontal movement to 25mm). Assemble these so that the slotted ends are above and below the expansion socket (Fig. 37)

Step 5

Incorporate the link eye (for attachment to drop rod or ceiling/soffit fixing) with the upper restraining bar.

Step 6

Check that the slotted end of each restraining bar is free to move, and tighten brackets so that they achieve a firm grip on the pipework.

Step 7

Connect assembly to drop rod and ceiling/soffit.

Cross Bracing

When branches enter a main run, cross bracing is necessary to stabilise the system.

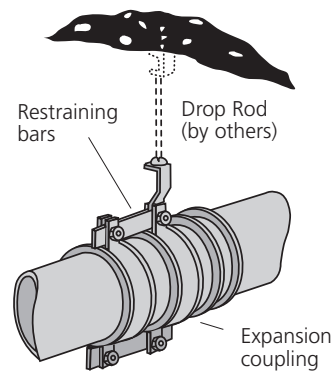

Fig. 36 Thermal Movement Limited (TML)

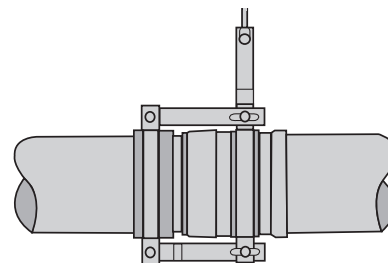

Fig. 37 TML collar and bars in position

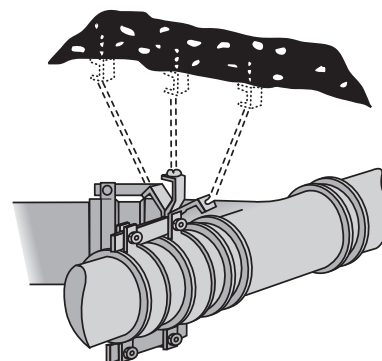



Fig. 38 TML assembly with cross bracing

Further information and assistance

Terrain products are backed by a comprehensive technical advisory service, available to provide advice and design guidance on all aspects of above and below ground drainage.

Technical services include:

- Soil and waste schematics and applicable details
- Specification, product scheduling and estimating
- CAD drawings, including products and application details on disk

Many products are also available in CAD form for ready incorporation into design drawings (Products marked in the listings with ). To obtain a disk or CD Rom in the appropriate format, simply contact Technical Services.

- On site advice and problem solving
- Prefabrication and fabrication design service

For prompt assistance, please contact the Terrain Technical Services Department:

Tel: 01622 795200

Fax: 01622 716796

Special component design service

For over 30 years our Fabrication Service has been helping specifiers and contractors overcome problems on site and at the design stage of projects. We can provide the solution to even the most demanding problems with specials fabricated to order.

Terrain Standard Specials

Created from modifications to standard products to meet frequently occurring design problems. These are identified with an F prefix in the product listing where applicable.

Terrain Design Specials

Products can be manufactured on a one-off or small batch basis to meet the demands of unique installations/ applications. These can be produced to customer specification in virtually any size or shape. Contact Technical Services for further assistance.

Materials and colours

Pipe and most fittings are manufactured in terracotta PVC-u.

Where other materials are used these are generally PP/PE.

Quality assurance

Terrain is accredited to BS EN ISO 9001:2000 Quality Management Systems.

Standards compliance

Terrain underground complies with the appropriate British Standard/ European Norm and, where applicable, is Kitemarked to BS EN 1401:1998.

The Inspection Chamber Base (4DI240B) and Raising Piece (4DI235R) meet the requirements of BS 7158:2001 for Plastic Inspection Chambers for drains.

Certifications

Foamcore pipe is covered by the following British Board of Agrément certificate:

95/3086

Eurodrain (Foamcore) Underground Drainage Pipe

Availability

For details of a wide range of stockists, please contact Sales Support on 01622 795200

Commercial Piping and Sanitary Systems



Polypipe Terrain

New Hythe Business Park
College Road
Aylesford
Kent ME20 7PJ
Tel: 01622 795200
Fax: 01622 716796

commercialenquiries@polypipe.com

www.polypipe.com

www.terraindrainage.com

Printed on material sourced from sustainable and well managed forests